

4

3

2

1

REVISION HISTORY			
REV	AUTH	DATE	DESCRIPTION
A	RL	2/25/16	INITIAL RELEASE

B

B

A

A

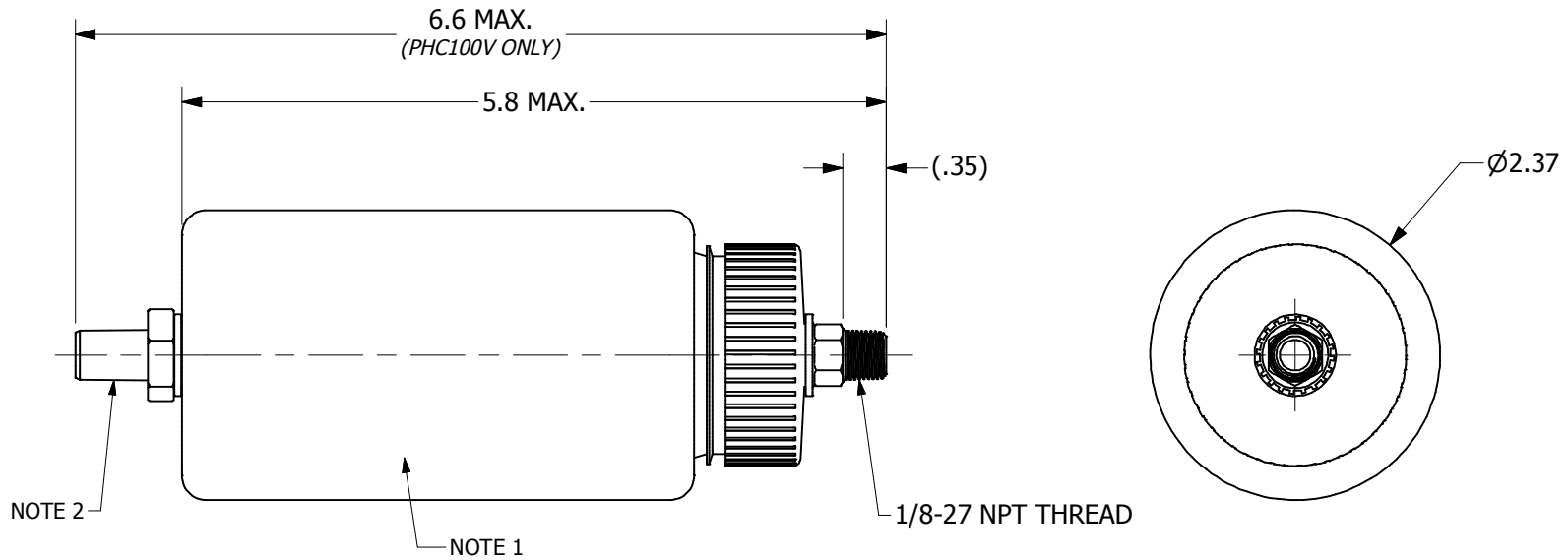

MODEL NUMBER: **PHC100** (STANDARD MODEL)
PHC100V (SELF-PUMPING MODEL)
 PRESSURE: **15 PSI RATED, 20 PSI MAX.**

NOTES:

1. BOTTLE CONTENTS WILL CHANGE COLOR FROM ORANGE TO GREEN TO INDICATE MOISTURE SATURATION. DESSICANT SHOULD THEN BE RECHARGED, OR UNIT REPLACED. CONSULT FACTORY FOR DETAILS.
2. INLET VALVE ON MODEL PHC100V ONLY.

4

3

2

1

USED ON:	QTY	NEXT ASSY	THIRD ANGLE PROJECTION	APPROVALS	DATE	ADVANCED TECHNICAL MATERIALS, INC. TEL: (631) 289-0363 FAX: (631) 289-0358 www.atmmicrowave.com	THE INFORMATION IN THIS DRAWING IS PROPRIETARY AND SHALL NOT BE USED OR DISCLOSED WITHOUT THE PRIOR WRITTEN CONSENT OF ATM, INC. DO NOT SCALE DWG.
			UNLESS OTHERWISE NOTED, DIMENSIONS ARE IN INCHES. TOLERANCES ARE: FRACTIONS: ±1/64 ANGLES: ±1/2° DECIMALS: 2 PLACE ±.01 3 PLACE ±.005 MACHINED FINISH IS ✓ OR BETTER.	DRAWN: RL DATE: 2-25-16 CHKD: APRVD:			
				MATERIAL	TREATMENT	SIZE: B CAGE CODE: ORSN4 ATM DWG #: 17216 MODEL #: SEE NOTES	REVISION: A SHEET: 1 OF 1