

REVISION HISTORY			DESCRIPTION
REV	AUTH	DATE	
A	BF	4-8-13	INITIAL RELEASE

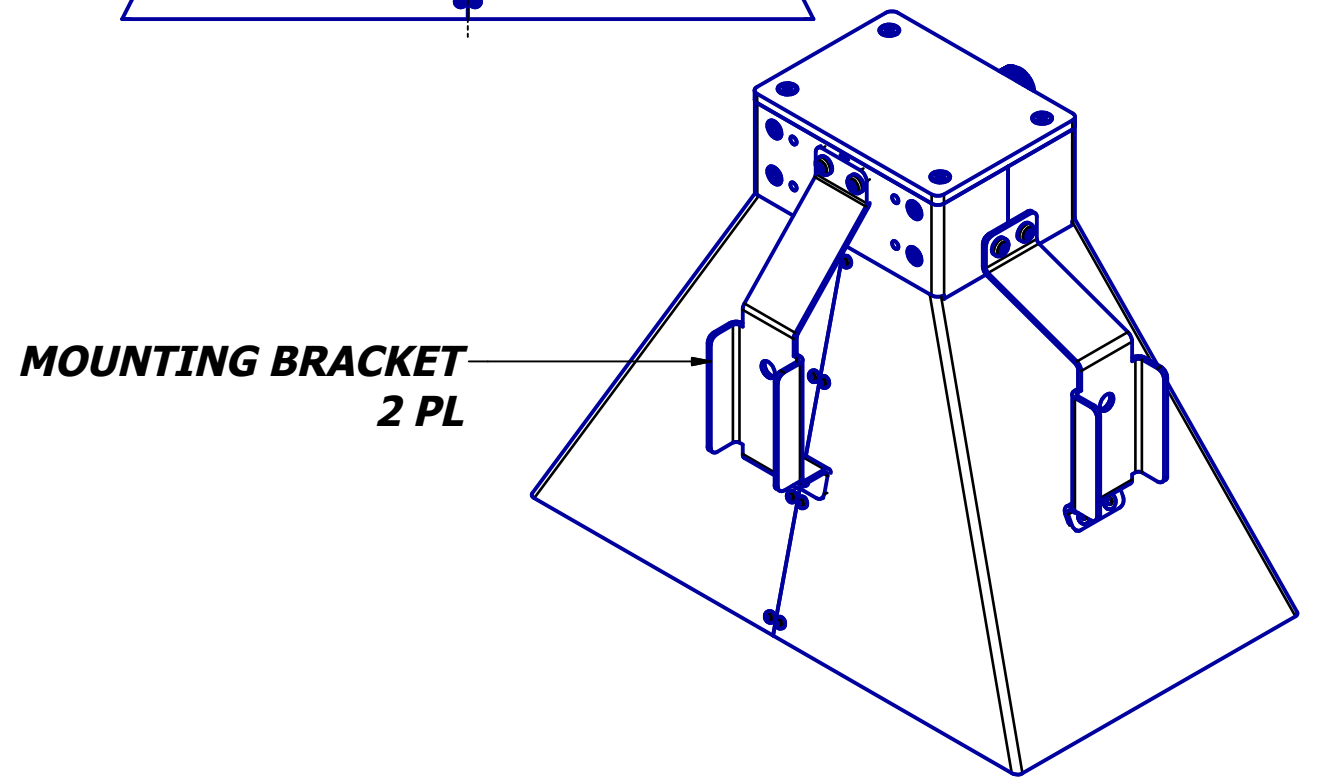
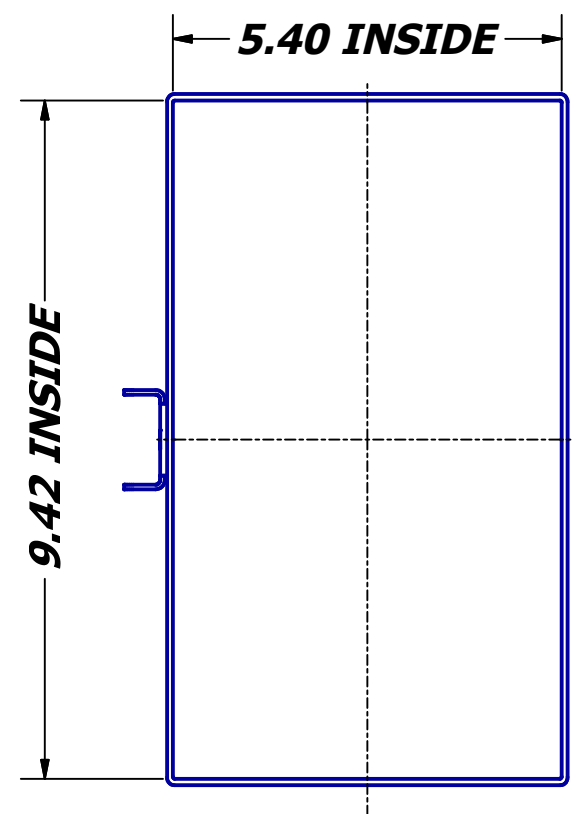
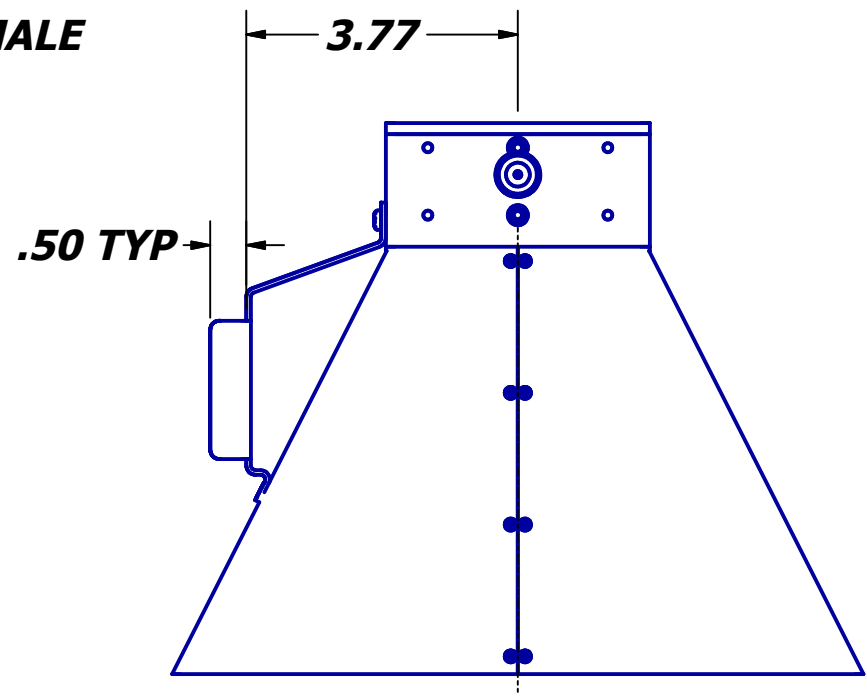
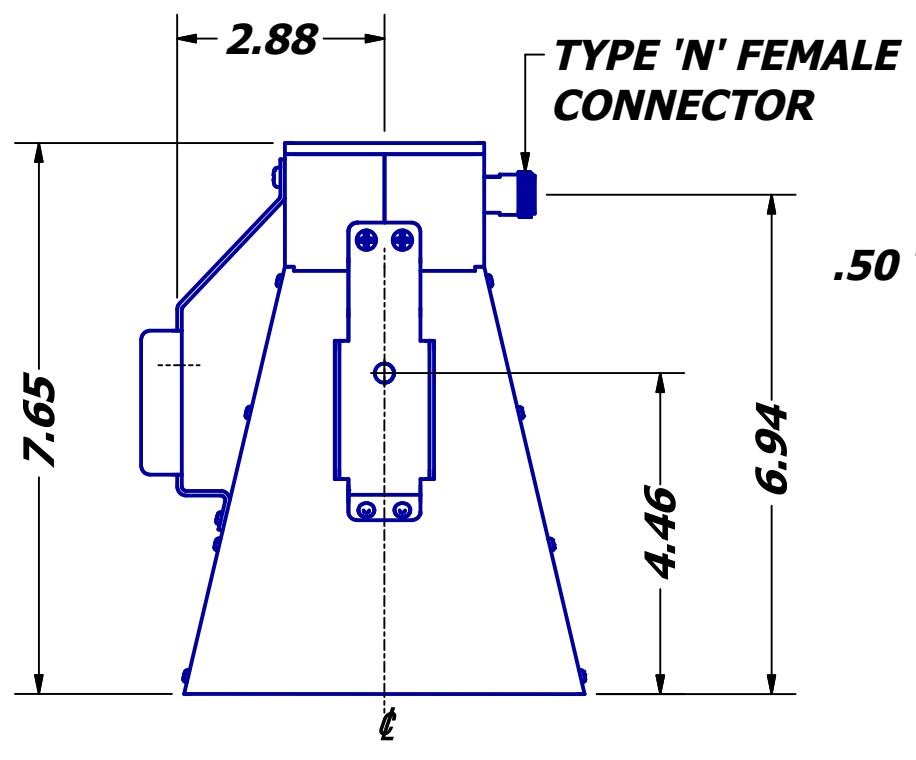
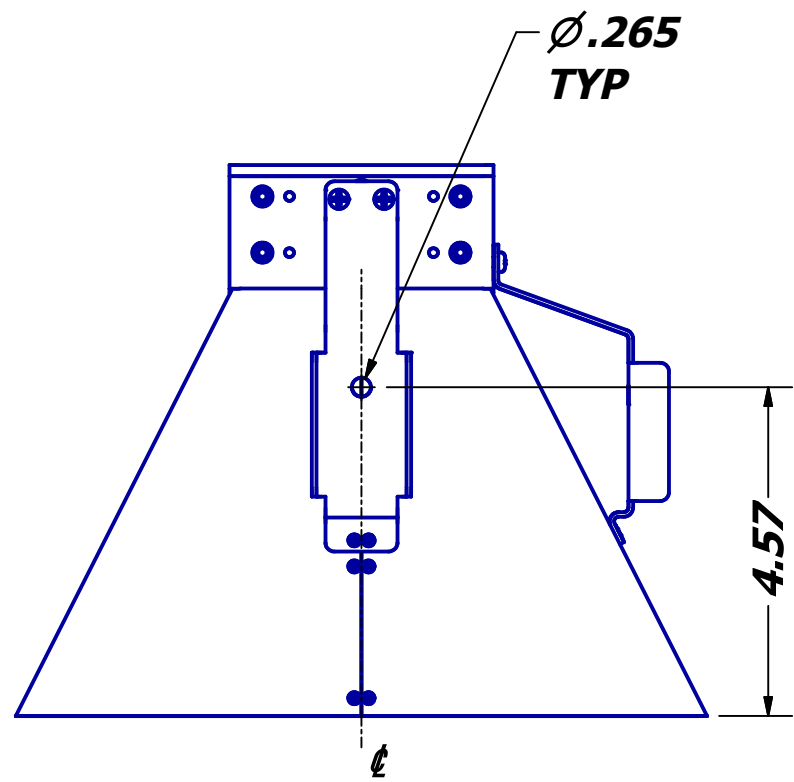

**NOTES;**

- 1. MODEL# 1-12-440EM-NF**
- 2. FREQUENCY: 1-12 GHz**
- 3. CONNECTOR: TYPE 'N' FEMALE**
- 4. NOMINAL GAIN: 8-12 dB**
- 5. VSWR: 2.5:1**

PO #	THIRD ANGLE PROJECTION:	APPROVALS	DATE	<b>ADVANCED TECHNICAL MATERIALS, INC.</b> TEL: (631) 289-0363 FAX: (631) 289-0358 www.atmmicrowave.com	<small>THE INFORMATION IN THIS DRAWING IS PROPRIETARY AND SHALL NOT BE USED OR DISCLOSED WITHOUT THE PRIOR WRITTEN CONSENT OF ATM, INC. DO NOT SCALE DWG.</small>
	UNLESS OTHERWISE NOTED, DIMENSIONS ARE IN INCHES. TOLERANCES ARE: FRACTIONS: $\pm 1/64$ ANGLES: $\pm 1^\circ$	DRAWN <b>BF</b> 4-8-13			
	DECIMALS 2 PLACE 3 PLACE <b><math>\pm .030</math></b> <b><math>\pm .010</math></b>	CHKD.		<b>OUTLINE, 1-12 GHz</b> <b>TYPE-N DOUBLE RIDGE HORN</b>	SIZE <b>B</b> CAGE CODE <b>OR8N4</b> ATM DWG # <b>14747</b> REVISION <b>A</b>
	MACHINED FINISH 63 $\checkmark$ OR BETTER	APRVD.			