

REV. A

DATE 6/5/04

PRODUCTION RELEASE

APPROVED MAB

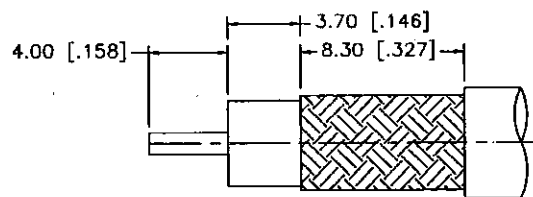
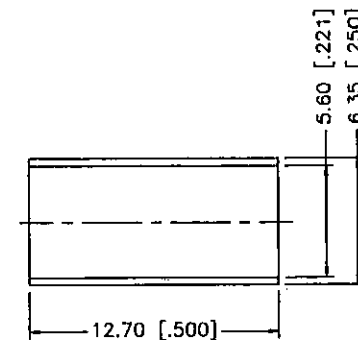
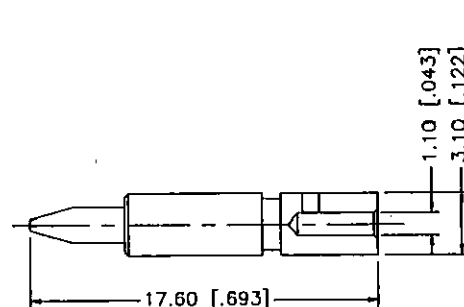
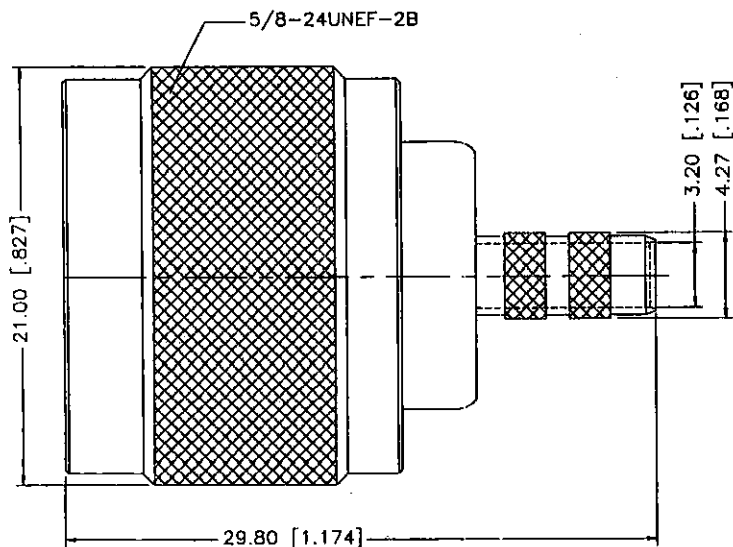

RECOMMENDED
CABLE STRIPPING DIM'S

NOTE:

1. CRIMPED FERRULE
HEX CRIMP SIZE .213"
2. CRIMPED CONTACT PIN
HEX CRIMP SIZE .105"

MATERIAL	TREATMENT	DRAWN	ACAD	DATE	6/3/04	
FINISH	MOD NO.	CHECKED	MAB	DATE	6/5/04	
TYPE N MALE CONNECTOR CF-160 CABLE ASSEMBLY PROCEDURE			APPROVED	MR	DATE	6/5/04
			CAGE CODE: ORB84			
ADVANCED TECHNICAL MATERIALS, INC. 49 RIDER AVE., PATCHOGUE N.Y. 11772 TEL: (631) 288-0386 FAX: (631) 289-0358 http://www.atmmicrowave.com			UNLESS OTHERWISE NOTED DIMENSIONS ARE IN INCHES TOLERANCES ARE:		SHEET.	
 PROPRIETARY NOTICE: THE INFORMATION IN THIS DRAWING IS PROPRIETARY AND SHALL NOT BE USED OR DISCLOSED WITHOUT THE PRIOR WRITTEN CONSENT OF ATM, INC.			FRACTIONS ±1/64 DECIMALS ±.01 ANGLES ±1/2°	SCALE 4:1 DWG. NO. NMC-160		REV. A