

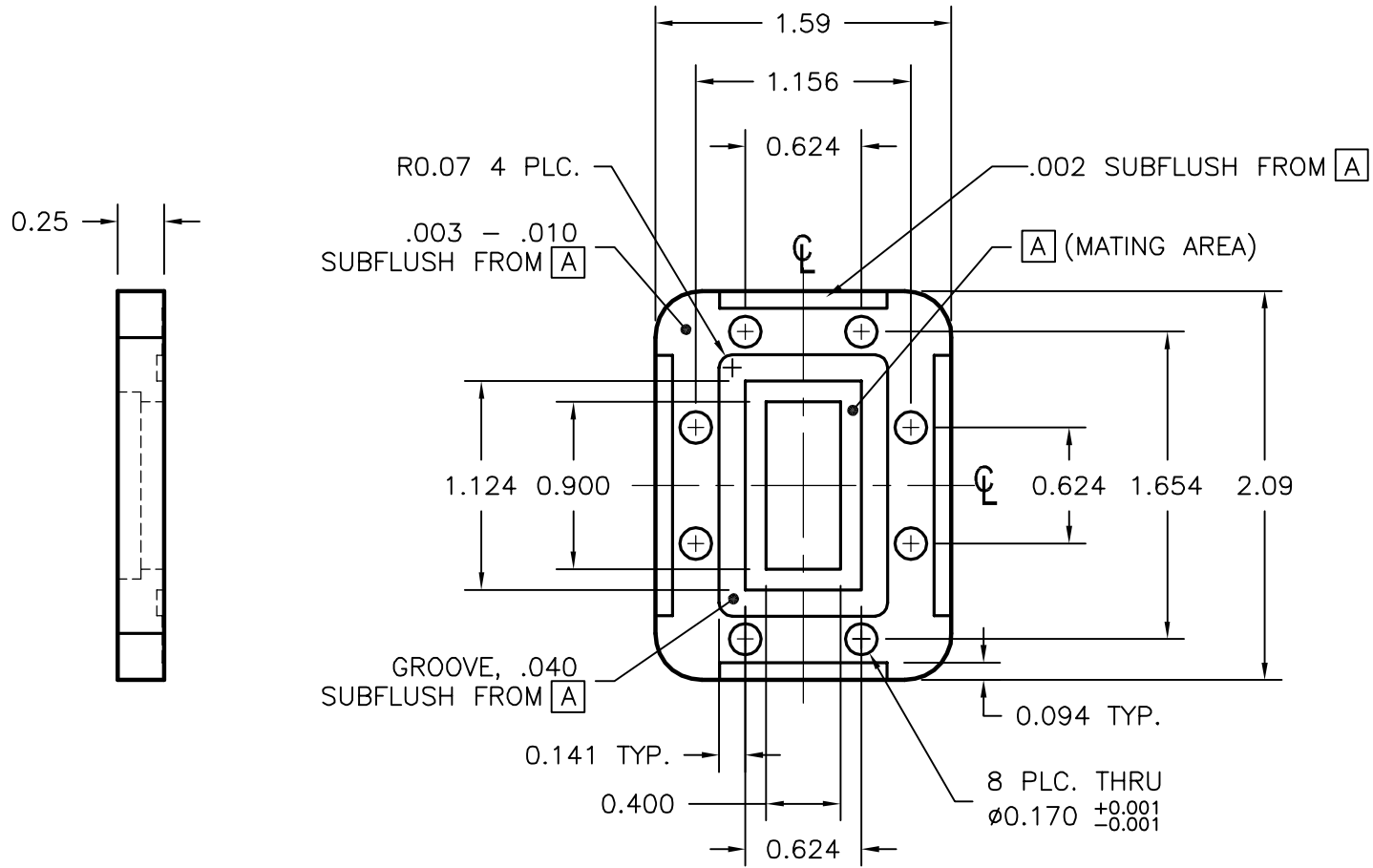

REV -	AUTH RL	DATE 03/02/07	INITIAL RELEASE
----------	------------	------------------	-----------------

MATERIAL	EQUIVALENT TO:		
BRASS	UG 1360/U	MIL-F-3922-52-043	PDR 100
ALUM.	UG 1361/U	MIL-F-3922-52-044	



NOTES:

- ALL DRAWINGS INDICATE APPLICABLE MATING DIMENSIONS. NON INTERFACE VARIABLES SUCH AS THICKNESS, CORRAL DIMENSIONS, AND MATERIALS MAY VARY DEPENDING ON PRODUCT CONFIGURATION.

THIRD ANGLE PROJECTION:		APPROVALS	DATE	 ADVANCED TECHNICAL MATERIALS, INC. TEL: (631) 289-0363 FAX: (631) 289-0358 www.atmmicrowave.com		<small>THE INFORMATION IN THIS DRAWING IS PROPRIETARY AND SHALL NOT BE USED OR DISCLOSED WITHOUT THE PRIOR WRITTEN CONSENT OF ATM, INC. DO NOT SCALE DWG.</small>			
UNLESS OTHERWISE NOTED, DIMENSIONS ARE IN INCHES. TOLERANCES ARE: FRACTIONS: $\pm 1/64$ ANGLES: $\pm 1/2^\circ$				DRAWN RL CHKD. APRVD.	03/02/07	<h1>CPR90G FLANGE</h1>			
BASIC DIMENSION	DECIMALS		MATERIAL	SIZE	CAGE CODE			ATM DWG #	REVISION
	2 PLACE	3 PLACE	-	A	0R8N4			7231W	-
UNDER 6"	$\pm .02$	$\pm .005$	TREATMENT	SCALE	1 : 1			MODEL #	SHEET
6" - 12"	$\pm .03$	$\pm .010$	-				1/1		
OVER 12"	$\pm .06$	$\pm .015$	FINISH						