

EQUIVALENT TO:

CPR159G	MATERIAL	MIL F-3922-	U/G TYPE
	ALUMINUM	52-038	UG 1355/U
	BRASS	52-037	UG 1354/U

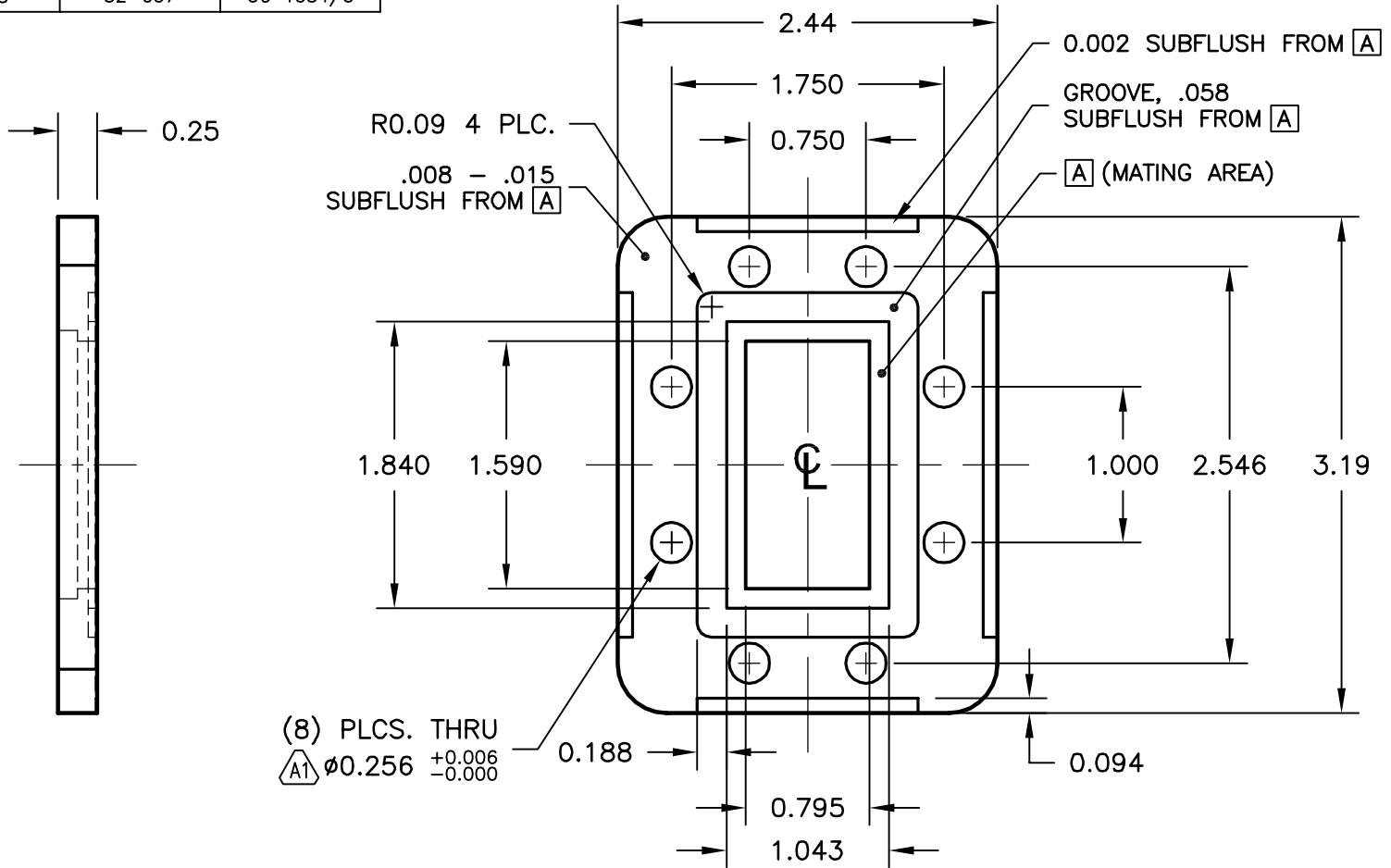

NOTES:

- ALL DRAWINGS INDICATE APPLICABLE MATING DIMENSIONS. NON INTERFACE VARIABLES SUCH AS THICKNESS, CORRAL DIMENSIONS, AND MATERIALS MAY VARY DEPENDING ON PRODUCT CONFIGURATION.

THIRD ANGLE PROJECTION:		APPROVALS	DATE	ADVANCED TECHNICAL MATERIALS, INC. TEL: (631) 289-0363 FAX: (631) 289-0358 www.atmmicrowave.com		THE INFORMATION IN THIS DRAWING IS PROPRIETARY AND SHALL NOT BE USED OR DISCLOSED WITHOUT THE PRIOR WRITTEN CONSENT OF ATM, INC. DO NOT SCALE DWG.	
UNLESS OTHERWISE NOTED, DIMENSIONS ARE IN INCHES, TOLERANCES ARE: FRACTIONS: ±1/64 ANGLES: ±1/2°		DRAWN -	07/18/07	CPR159G FLANGE			
BASIC DIMENSION	DECIMALS 2 PLACE 3 PLACE	CHKD.	APRVD.	SIZE A	CAGE CODE 0R8N4	ATM DWG # 7235W	REVISION A
UNDER 6"	±.02 ±.005	MATERIAL -		SCALE NONE	MODEL # -		SHEET 1/1
6" - 12"	±.03 ±.010	TREATMENT -					
OVER 12"	±.06 ±.015	FINISH -					