

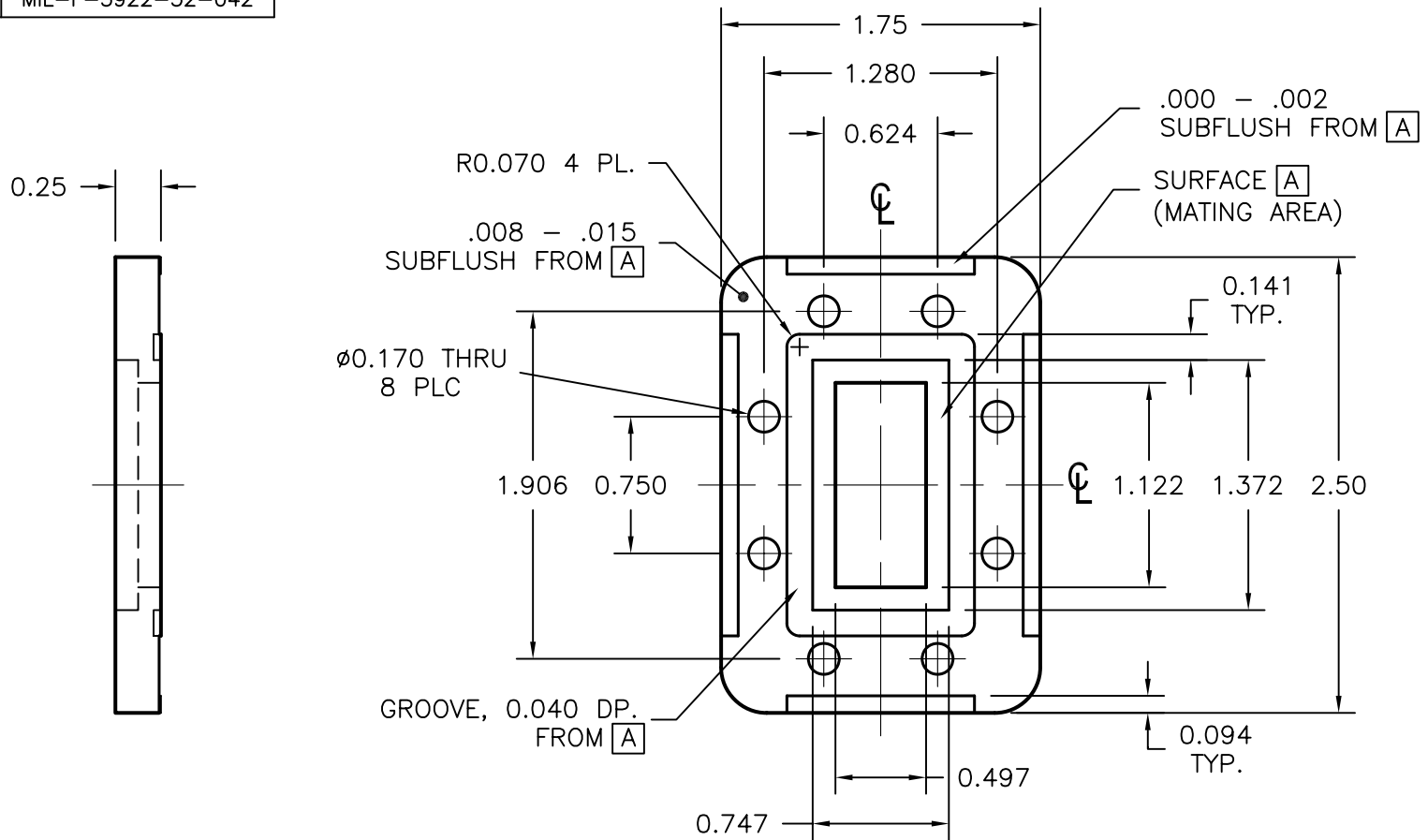

MATERIAL	EQUIVALENT TO:	
BRASS	UG 1358/U	MIL-F-3922-52-041
ALUM.	UG 1359/U	MIL-F-3922-52-042



NOTES:

- ALL DRAWINGS INDICATE APPLICABLE MATING DIMENSIONS. NON INTERFACE VARIABLES SUCH AS THICKNESS, CORRAL DIMENSIONS, AND MATERIALS MAY VARY DEPENDING ON PRODUCT CONFIGURATION.

THIRD ANGLE PROJECTION:			APPROVALS	DATE	 ADVANCED TECHNICAL MATERIALS, INC. TEL: (631) 289-0363 FAX: (631) 289-0358 www.atmmicrowave.com			<small>THE INFORMATION IN THIS DRAWING IS PROPRIETARY AND SHALL NOT BE USED OR DISCLOSED WITHOUT THE PRIOR WRITTEN CONSENT OF ATM, INC. DO NOT SCALE DWG.</small>				
UNLESS OTHERWISE NOTED, DIMENSIONS ARE IN INCHES. TOLERANCES ARE: FRACTIONS: ±1/64 ANGLES: ±1/2°			DRAWN M.R.	8/4/09	WR112 FLANGE, CPR112G			REVISION A				
BASIC DIMENSION			CHKD.					SIZE A			CAGE CODE OR8N4	
DECIMALS 2 PLACE 3 PLACE			APRVD.					ATM DWG # 9937			MODEL # -	
UNDER 6"	±.02	±.005	MATERIAL SEE NOTES		SCALE 1 : 1			SHEET 1/1				
6" - 12"	±.03	±.010	TREATMENT -									
OVER 12"	±.06	±.015	FINISH -									