

EQUIVALENT TO:

MATERIAL	UG TYPE	MIL F-3922
ALUMINUM	UG-600 A/U	59-005
BRASS		

REV. -	AUTH. RL	DATE 08/02/05	INITIAL RELEASE	APPROVED
--------	----------	---------------	-----------------	----------

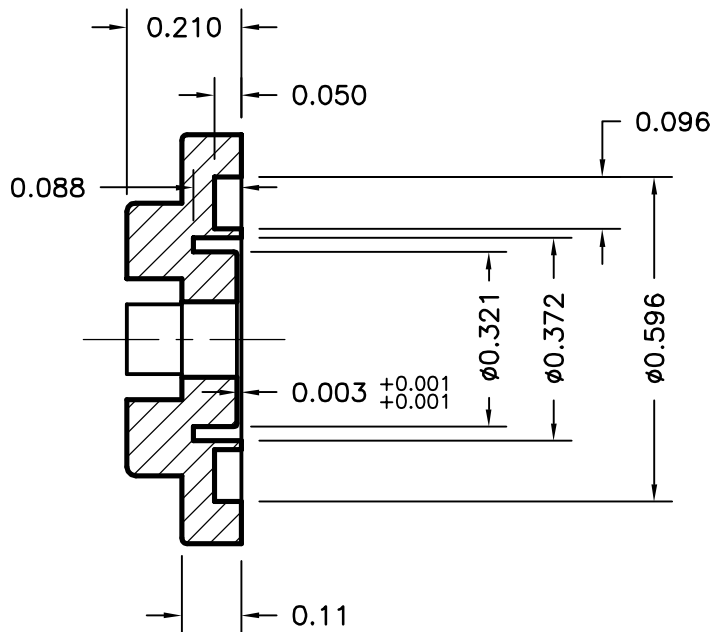

SECTION A-A

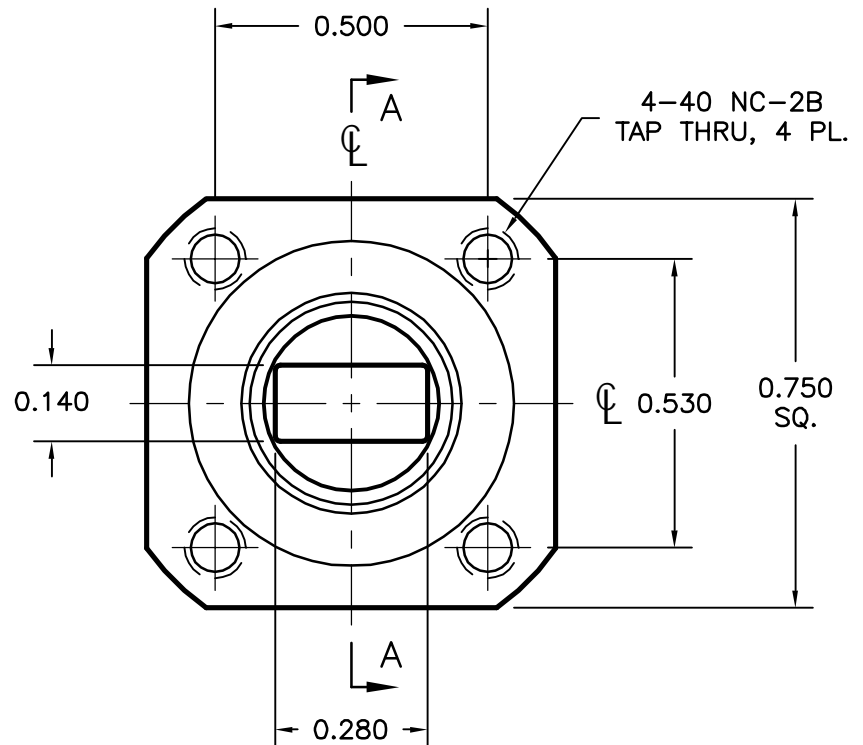

NOTES:

1. ALL DRAWINGS INDICATE APPLICABLE MATING DIMENSIONS. NON INTERFACE VARIABLES SUCH AS THICKNESS, CORRAL DIMENSIONS, AND MATERIALS MAY VARY DEPENDING ON PRODUCT CONFIGURATION.

MATERIAL	SEE TABLE	TREATMENT	-	DRAWN	RL	DATE	08/02/05
FINISH	-	MOD NO.	-	CHECKED		DATE	
WR28 CHOKE FLG.						APPROVED	DATE
						CAGE CODE: OR8N4	DO NOT SCALE DWG
ADVANCED TECHNICAL MATERIALS, INC. 49 RIDER AVE., PATCHOGUE N.Y. 11772 TEL: (631) 289-0363 FAX: (631) 289-0358 http://www.atmmicrowave.com				UNLESS OTHERWISE NOTED DIMENSIONS ARE IN INCHES TOLERANCES ARE:		FRACTIONS ±1/64 DECIMALS ±.02 ANGLES ±1/2°	SHEET. 1/1
PROPRIETARY NOTICE: THE INFORMATION IN THIS DRAWING IS PROPRIETARY AND SHALL NOT BE USED OR DISCLOSED WITHOUT THE PRIOR WRITTEN CONSENT OF ATM, INC.				SCALE NONE	DWG. NO. 7262W	REV. -	