

EQUIVALENT TO;

TYPE	MATERIAL
UG 407/U	ALUMINUM
UG 149A/U	BRASS

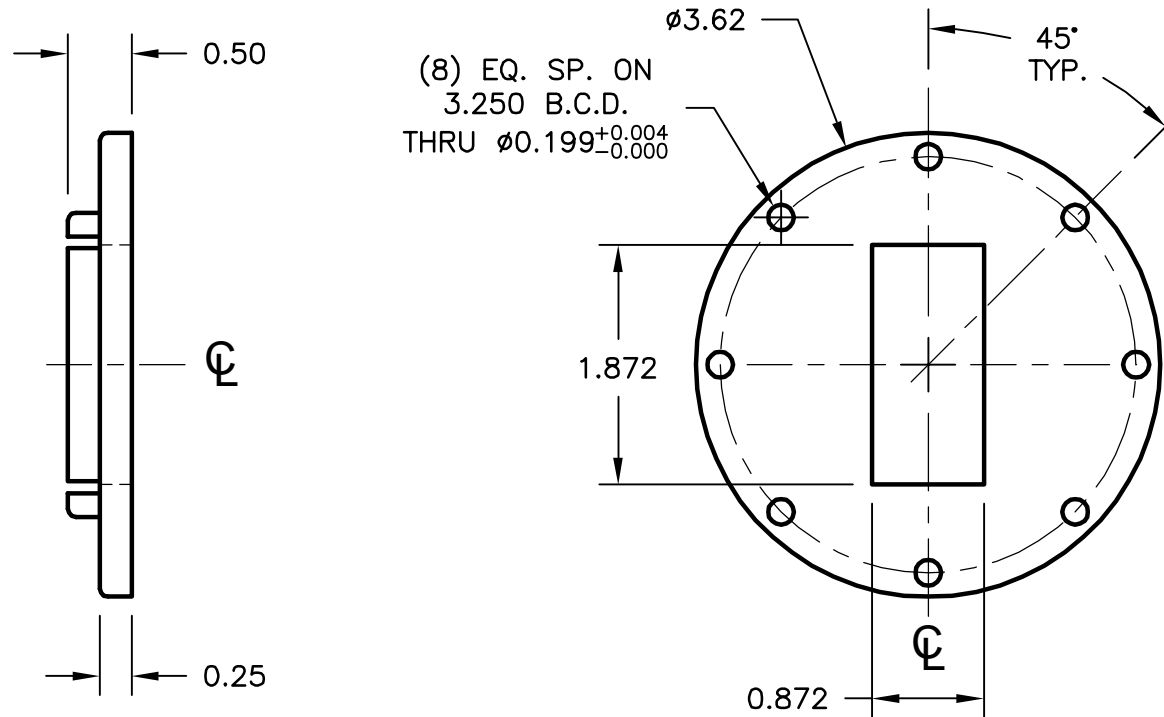

NOTES:

1. FLANGE SHOWN IS ATM STANDARD FLANGE FOR WAVEGUIDE TYPE NOTED. OTHER FLANGE TYPES ARE AVAILABLE UPON REQUEST.
2. ALL DRAWINGS INDICATE APPLICABLE MATING DIMENSIONS. NON INTERFACE VARIABLES SUCH AS THICKNESS, CORRAL DIMENSIONS, AND MATERIALS MAY VARY DEPENDING ON PRODUCT CONFIGURATION.

MATERIAL	SEE NOTES	TREATMENT	-	DRAWN	DRH	DATE	12/13/04
FINISH	-	MOD NO.	-	CHECKED		DATE	
WR187 COVER FLANGE						APPROVED	DATE
						CAGE CODE: OR8N4	DO NOT SCALE DWG
ADVANCED TECHNICAL MATERIALS, INC. 49 RIDER AVE., PATCHOGUE N.Y. 11772 TEL: (631) 289-0363 FAX: (631) 289-0358 http://www.atmmicrowave.com				UNLESS OTHERWISE NOTED DIMENSIONS ARE IN INCHES TOLERANCES ARE:		FRACTIONS ±1/64 DECIMALS ±.01 ANGLES ±1/2°	SHEET. 1/1
						SCALE N.T.S.	DWG. NO. 7061W
PROPRIETARY NOTICE: THE INFORMATION IN THIS DRAWING IS PROPRIETARY AND SHALL NOT BE USED OR DISCLOSED WITHOUT THE PRIOR WRITTEN CONSENT OF ATM, INC.						REV. -	