

REVISION HISTORY			
REV	AUTH	DATE	DESCRIPTION
A	RL	12/30/2014	INITIAL RELEASE

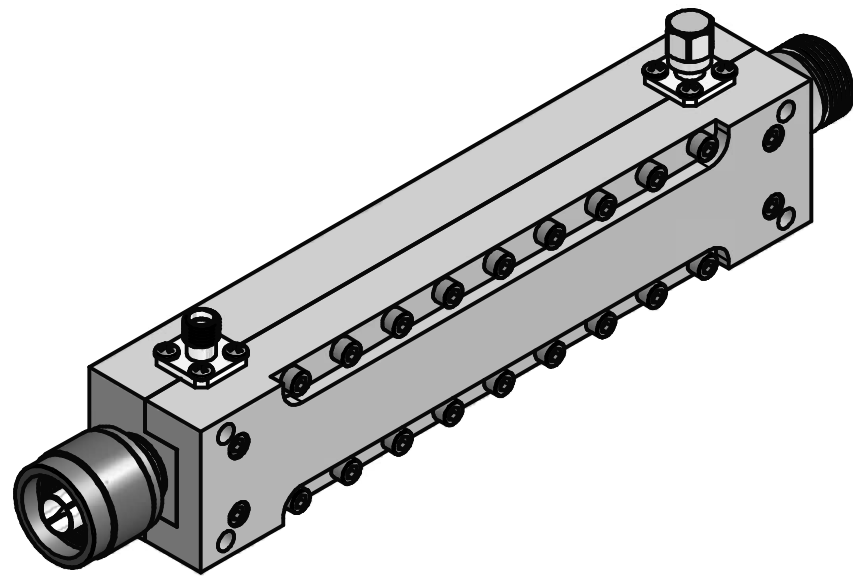

**ISO VIEW**

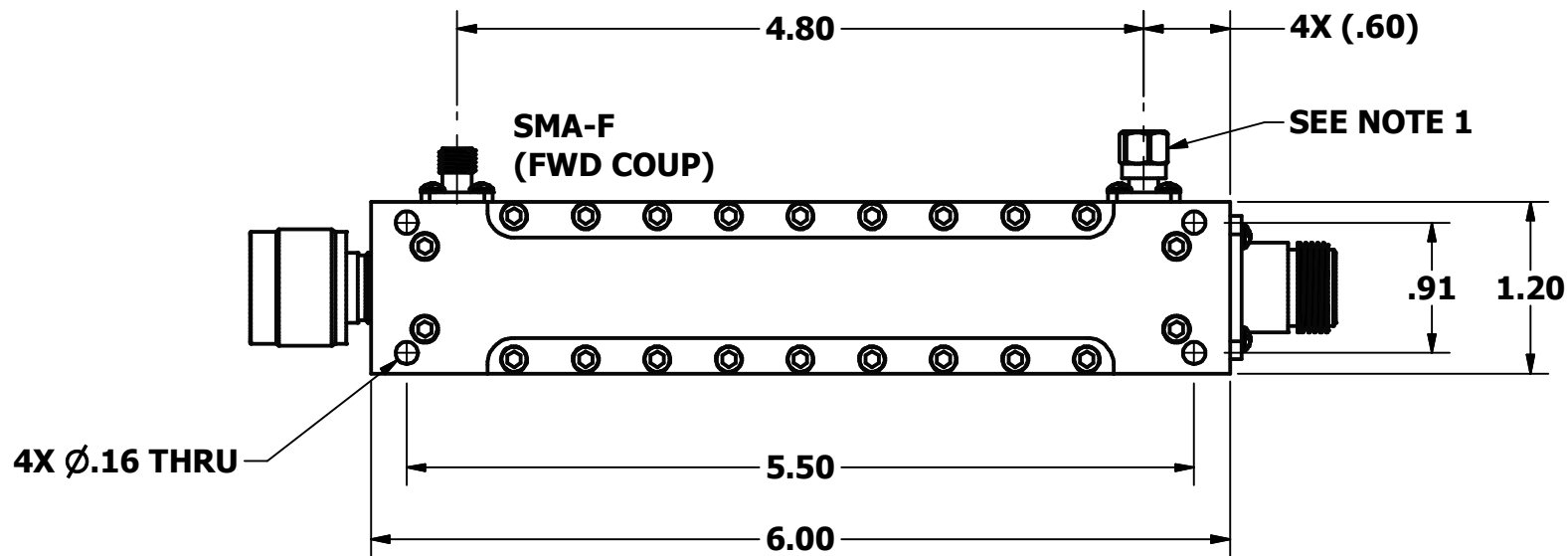
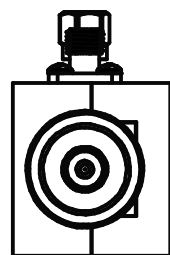
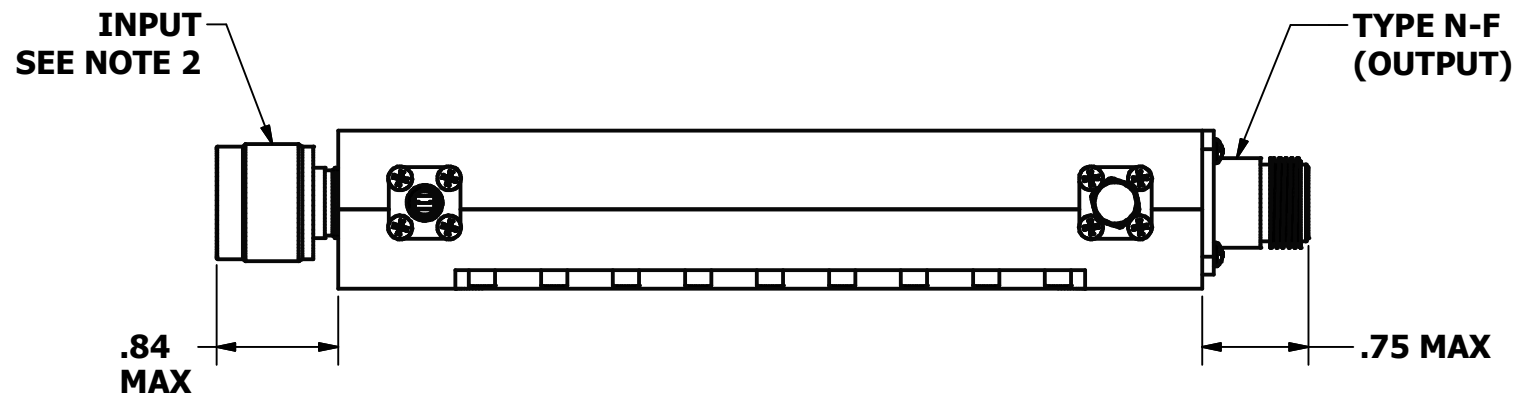

**NOTES:**

- SECONDARY TERMINATIONS CAN BE INTERNAL OR EXTERNAL DEPENDING ON MODEL AND SHOULD NOT BE REMOVED. FOR CONNECTORIZED LOADS CONSULT FACTORY.**
- TYPE N-(M) SHOWN. OTHER CONNECTORS AVAILABLE UPON REQUEST.**

MODEL NO	QTY	NEXT ASSY	THIRD ANGLE PROJECTION:	APPROVALS	DATE	 <b>ADVANCED TECHNICAL MATERIALS, INC.</b> <small>TEL: (631) 289-0363 FAX: (631) 289-0358 www.atmmicrowave.com</small>			<small>THE INFORMATION IN THIS DRAWING IS PROPRIETARY AND SHALL NOT BE USED OR DISCLOSED WITHOUT THE PRIOR WRITTEN CONSENT OF ATM, INC. DO NOT SCALE DWG.</small>			
			<small>UNLESS OTHERWISE NOTED, DIMENSIONS ARE IN INCHES. TOLERANCES ARE: FRACTIONS: ±1/64 ANGLES: ±1/2°</small>	DRAWN	RL	12/30/2014	<b>OUTLINE,</b> <b>CHP272D AIRLINE COUP, SING, .5 - 2.0 GHz</b>			SIZE	B	
				DECIMALS 2 PLACE   3 PLACE <b>±.01</b>   <b>±.005</b>	CHKD.						CAGE CODE	0R8N4
			MACHINED FINISH 63 ✓ OR BETTER	APRVD.			MODEL #	<b>CHP272D-XX</b>			SHEET	1 OF 1