

REV. A	AUTH. R.L.	DATE 2/10/01	INITIAL RELEASE	APPROVED
REV. B	AUTH. R.L.	DATE 3/15/04	ADDED LOCKING COLLAR	APPROVED
REV. C	AUTH. R.L.	DATE 9/25/02	ADDED LOCKING COLLAR AND KNOB OPTION	APPROVED
REV. D	AUTH. R.L.	DATE 1/19/05	FORMAT UPDATE	APPROVED

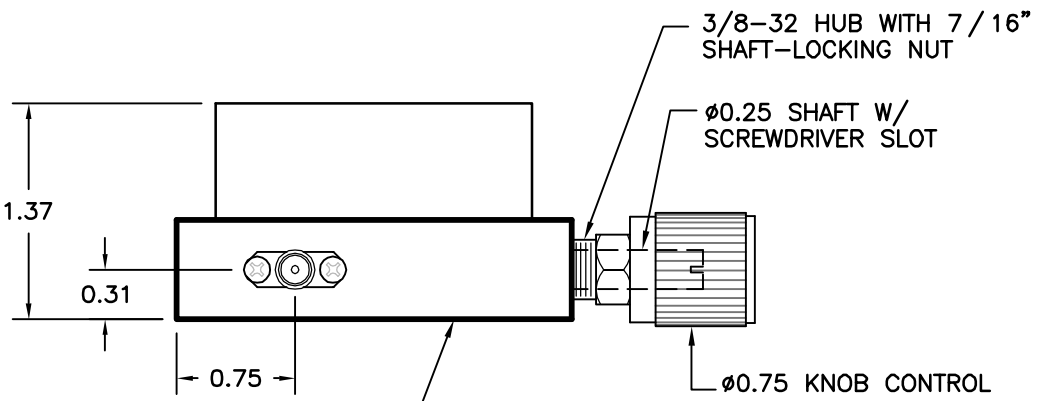
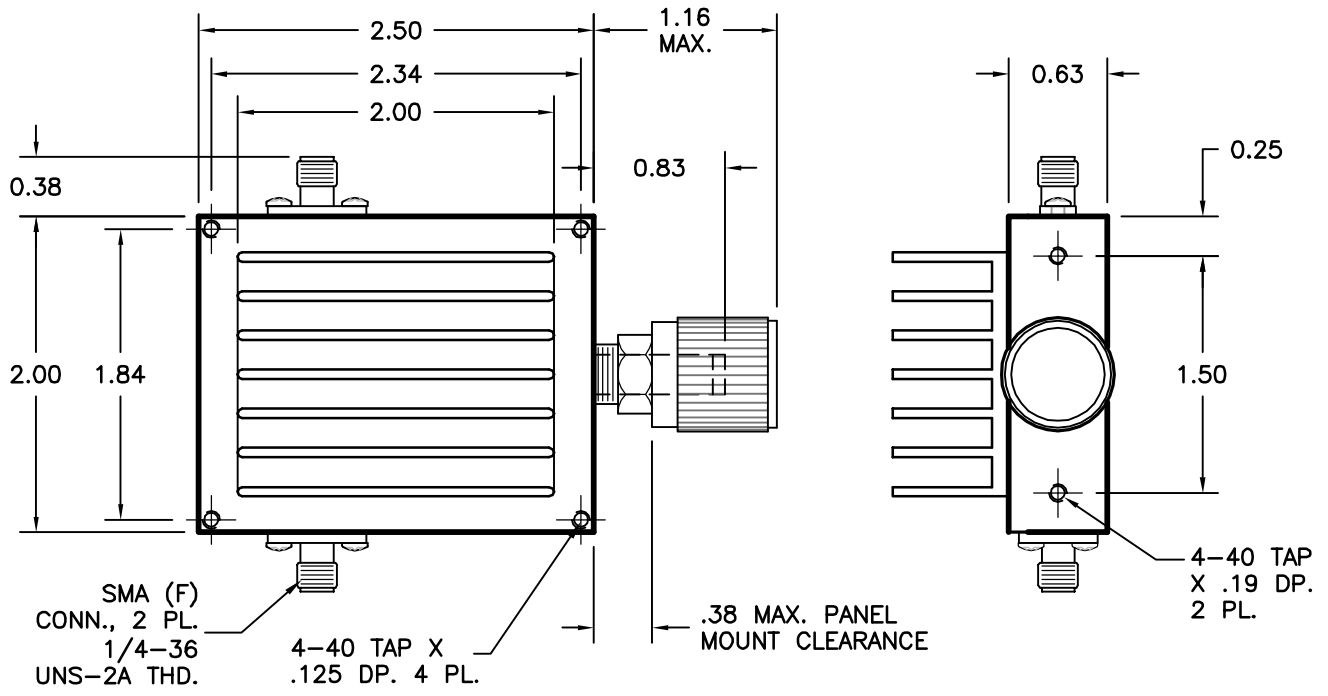

NOTE: SURFACE REQUIRES HEATSINK, NO PAINT.

MATERIAL	ALUM.	TREATMENT	-	DRAWN	R. LYNCH	DATE	1/19/05
FINISH	ATM STD. GREY	MOD NO.	AH30V08X	CHECKED		DATE	
<p style="text-align: center;"><b>OUTLINE, 50W CONTINUOUSLY VARIABLE COAX ATTENUATOR</b></p>				APPROVED		DATE	
				CAGE CODE: OR8N4		DO NOT SCALE DWG	
<p>ADVANCED TECHNICAL MATERIALS, INC. 49 RIDER AVE., PATCHOGUE N.Y. 11772 TEL: (631) 289-0363 FAX: (631) 289-0358 <a href="http://www.atmmicrowave.com">http://www.atmmicrowave.com</a></p>				<p>UNLESS OTHERWISE NOTED DIMENSIONS ARE IN INCHES TOLERANCES ARE:</p>		<p>FRACTIONS ±1/64</p> <p>DECIMALS ±.01</p> <p>ANGLES ±1/2°</p>	<p>SHEET. 1/1</p>
<p>PROPRIETARY NOTICE: THE INFORMATION IN THIS DRAWING IS PROPRIETARY AND SHALL NOT BE USED OR DISCLOSED WITHOUT THE PRIOR WRITTEN CONSENT OF ATM, INC.</p>				<p>SCALE NONE</p>	<p>DWG. NO. 4235</p>	<p>REV. D</p>	