

REV -	AUTH RL	DATE 10/3/06	INITIAL RELEASE
A	DM	04/11/07	ADDED WRD180 TO CHART ; UPDATED TITLE BLOCK

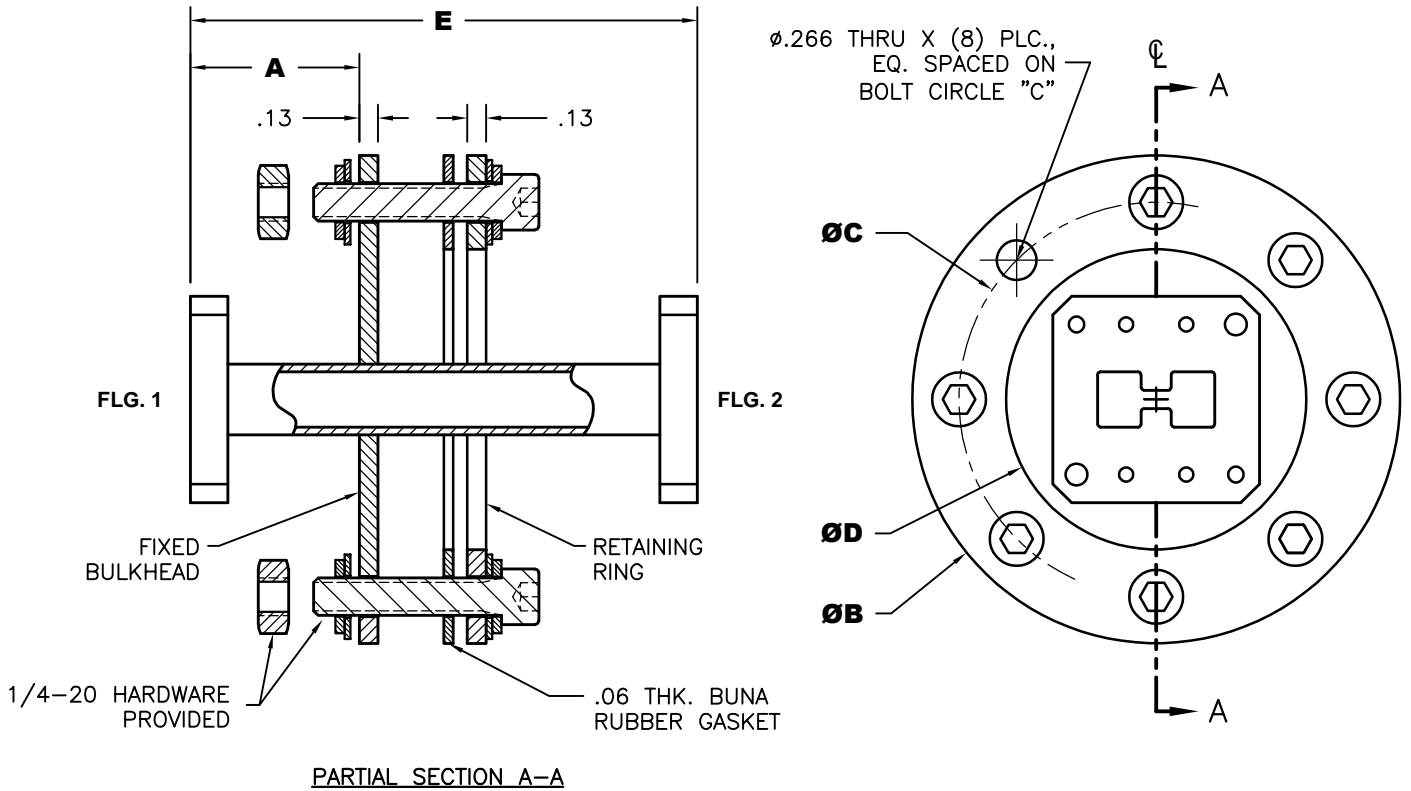

WRD	DIM. A	DIM. B	DIM. C	DIM. D	DIM. E
180	1.00	3.00	2.500	1.88	3.00
250	1.63	5.25	4.625	3.75	5.00
350	1.63	5.25	4.625	3.75	5.00
475	1.38	3.50	2.875	2.25	3.75
580	1.38	3.50	2.875	2.25	3.75
650	1.38	3.50	2.875	2.25	3.75
750	1.38	3.50	2.875	2.25	3.75

THIRD ANGLE PROJECTION:		APPROVALS	DATE	ADVANCED TECHNICAL MATERIALS, INC. TEL: (631) 289-0363 FAX: (631) 289-0358 www.atmmicrowave.com		THE INFORMATION IN THIS DRAWING IS PROPRIETARY AND SHALL NOT BE USED OR DISCLOSED WITHOUT THE PRIOR WRITTEN CONSENT OF ATM, II DO NOT SCALE DWG.	
UNLESS OTHERWISE NOTED, DIMENSIONS ARE IN INCHES, TOLERANCES ARE: FRACTIONS: ±1/64 ANGLES: ±1/2°		DRAWN RL	10/03/06	<p style="text-align: center;">TABULATED OUTLINE, WRD W/G BULKHEAD FEEDTHRU</p>			
BASIC DIMENSION		CHKD.					
DECIMALS 2 PLACE 3 PLACE		APRVD.					
UNDER 6"	±.02 ±.005	MATERIAL PER ORDER		SIZE A	CAGE CODE 0R8N4	ATM DWG # 6893W	REVISION A
6" - 12"	±.03 ±.010	TREATMENT -		SCALE	NONE	MODEL # XXX-130-XX-XX-XX	SHEET 1/1
OVER 12"	±.06 ±.015	ATM GREY					