

REVISION HISTORY

REV	AUTH	DATE	DESCRIPTION
A	RL	1-16-2017	INITIAL RELEASE

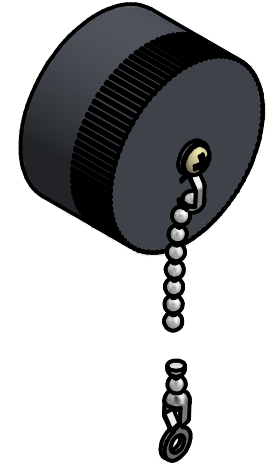
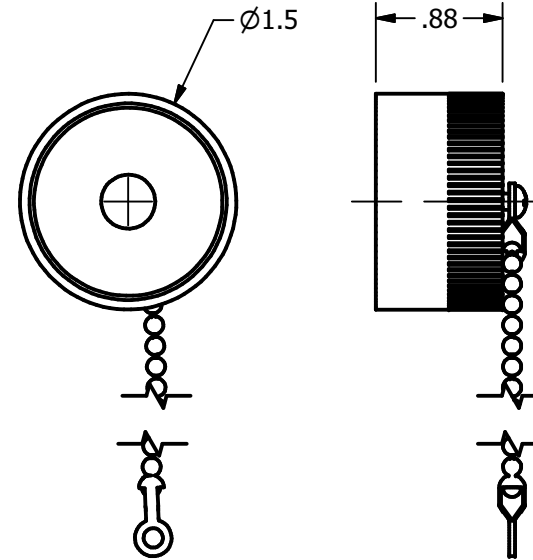
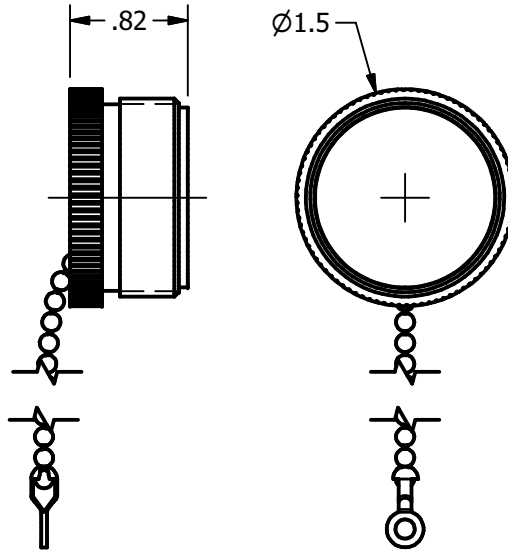

DUST COVER, MALE

NOTE: MATES TO FEMALE END OF QD-42HQ QUICK CONNECT ASSEMBLY.

MODEL #: **QD-42-MDC**
 MATERIAL: ALUM.
 FINISH: BLACK ANODIZE

DUST COVER, FEMALE

NOTE: MATES TO MALE END OF QD-42HQ QUICK CONNECT ASSEMBLY.

MODEL #: **QD-42-FDC**
 MATERIAL: ALUM.
 FINISH: BLACK ANODIZE

USED ON:	QTY	NEXT ASSY	THIRD ANGLE PROJECTION:	DRAWN: RL	DATE: 1-16-17
			UNLESS OTHERWISE NOTED, DIMENSIONS ARE IN INCHES, TOLERANCES ARE: FRACTIONS: ±1/64 ANGLES: ±1/2°	CHKD.	
			DECIMALS 2 PLACE 3 PLACE	APRVD.	
			±.01 ±.005	MATERIAL	SEE NOTE
SHEET SIZE: A			SHEET #: 1 OF 1	TREATMENT	-
				FINISH	SEE NOTE
				SURFACE FINISH:	63 √ OR BETTER



L3-NARDA-ATM
 49 Rider Ave, Patchogue, NY 11772
 TEL: (631) 289-0363 FAX: (631) 289-0358
 www.atmmicrowave.com
 CAGE CODE: 0R8N4

THE INFORMATION IN THIS DRAWING IS PROPRIETARY AND SHALL NOT BE USED OR DISCLOSED WITHOUT THE PRIOR WRITTEN CONSENT OF L3 NARDA-ATM, INC.

OUTLINE, DUST COVERS
 WR42 QUICK CONNECTS

MODEL # SEE NOTE	ATM DWG # 17869	REVISION A
---------------------	--------------------	---------------