

REV A	AUTH M.R.	DATE 6/30/09	INITIAL RELEASE
REV B	AUTH M.R.	DATE 7/30/09	ADDED WIDTH (1.00) DIMENSION

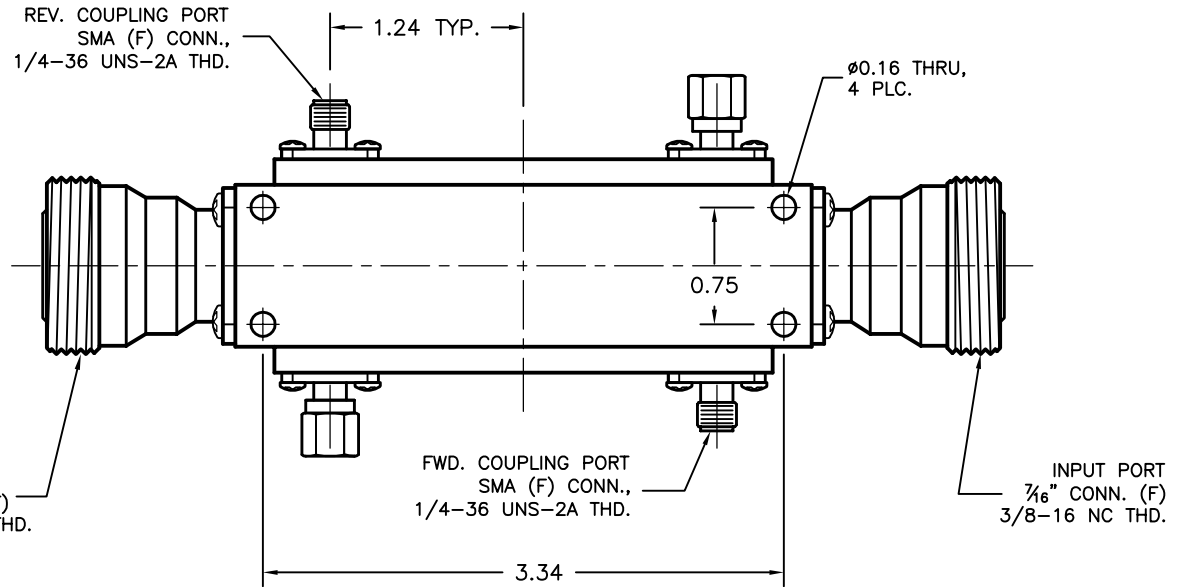
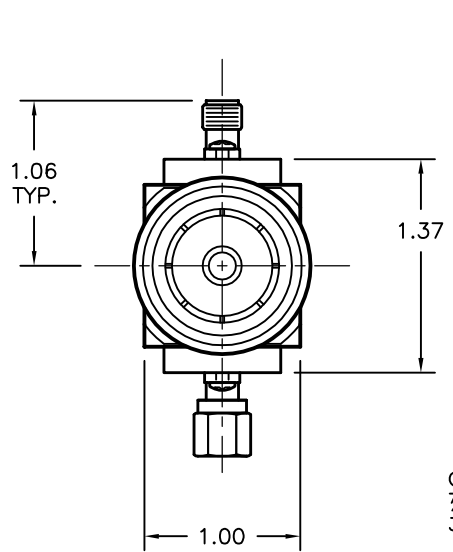
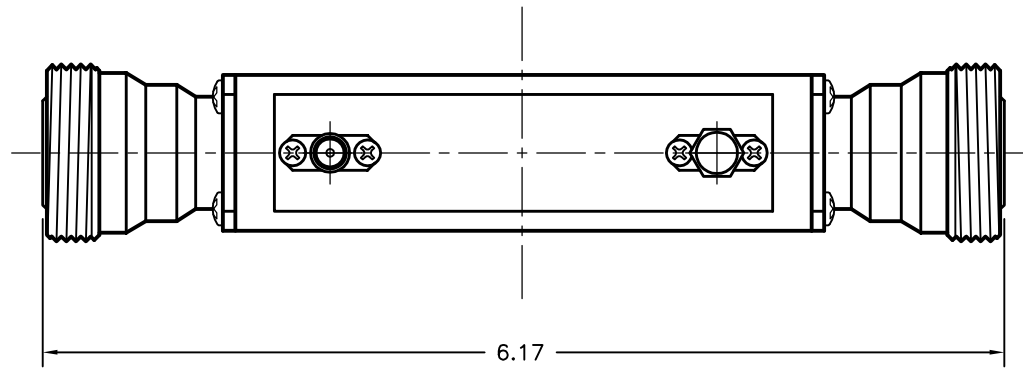

THIRD ANGLE PROJECTION:			APPROVALS	DATE	ADVANCED TECHNICAL MATERIALS, INC. TEL: (631) 289-0363 FAX: (631) 289-0358 www.atmmicrowave.com	<small>THE INFORMATION IN THIS DRAWING IS PROPRIETARY AND SHALL NOT BE USED OR DISCLOSED WITHOUT THE WRITTEN CONSENT OF ATM. I DO NOT SCALE DWG.</small>			
UNLESS OTHERWISE NOTED, DIMENSIONS ARE IN INCHES. TOLERANCES ARE: FRACTIONS: ±1/64 ANGLES: ±1/2°			DRAWN M.R. CHKD. APRVD.	6/30/09		OUTLINE HIGH POWER DIR. COUP.		REVISION B	
BASIC DIMENSION	DECIMALS 2 PLACE 3 PLACE		MATERIAL -		SIZE A			CAGE CODE 0R8N4	ATM DWG # 9839
UNDER 6"	±.02	±.005	TREATMENT IRIDITE		SCALE 1 : 1			MODEL # CHP(7/16)73E-XXF-XXR	SHEET 1/1
6" - 12"	±.04	±.010	MATERIAL ATM GRAY						
OVER 12"	±.06	±.015							