

REVISION HISTORY			
REV	BY	DESCRIPTION	DATE
A	RL	INITIAL RELEASE	6/2/18

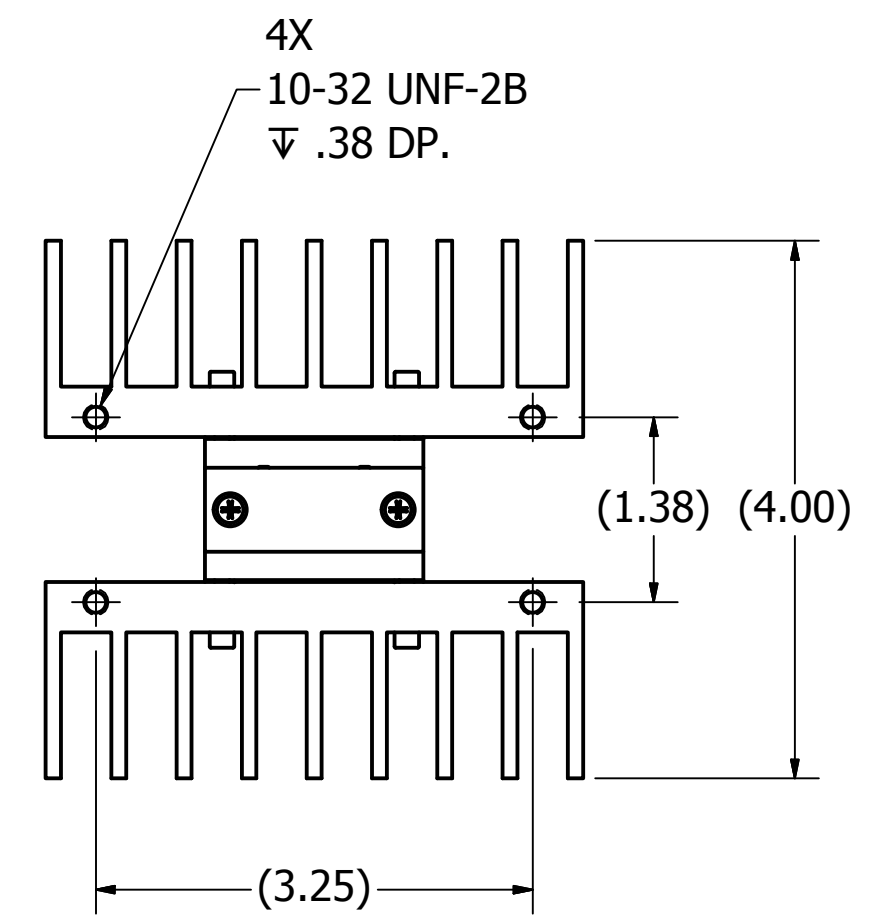
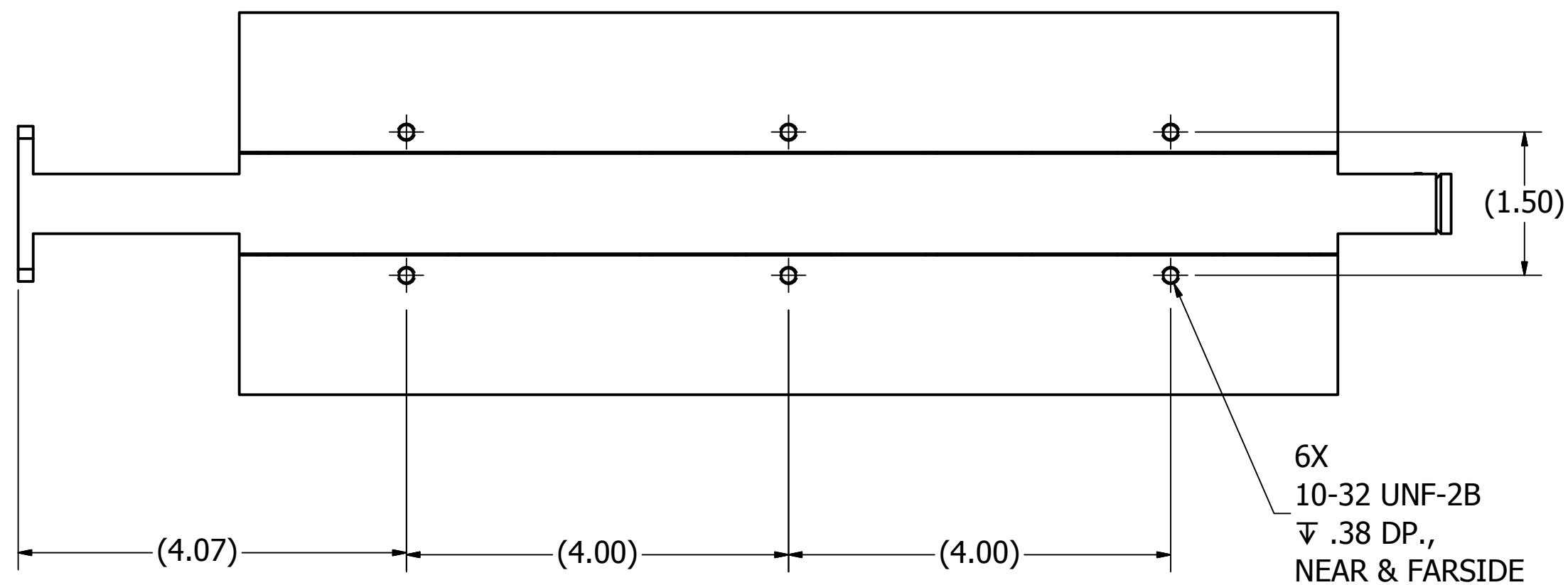
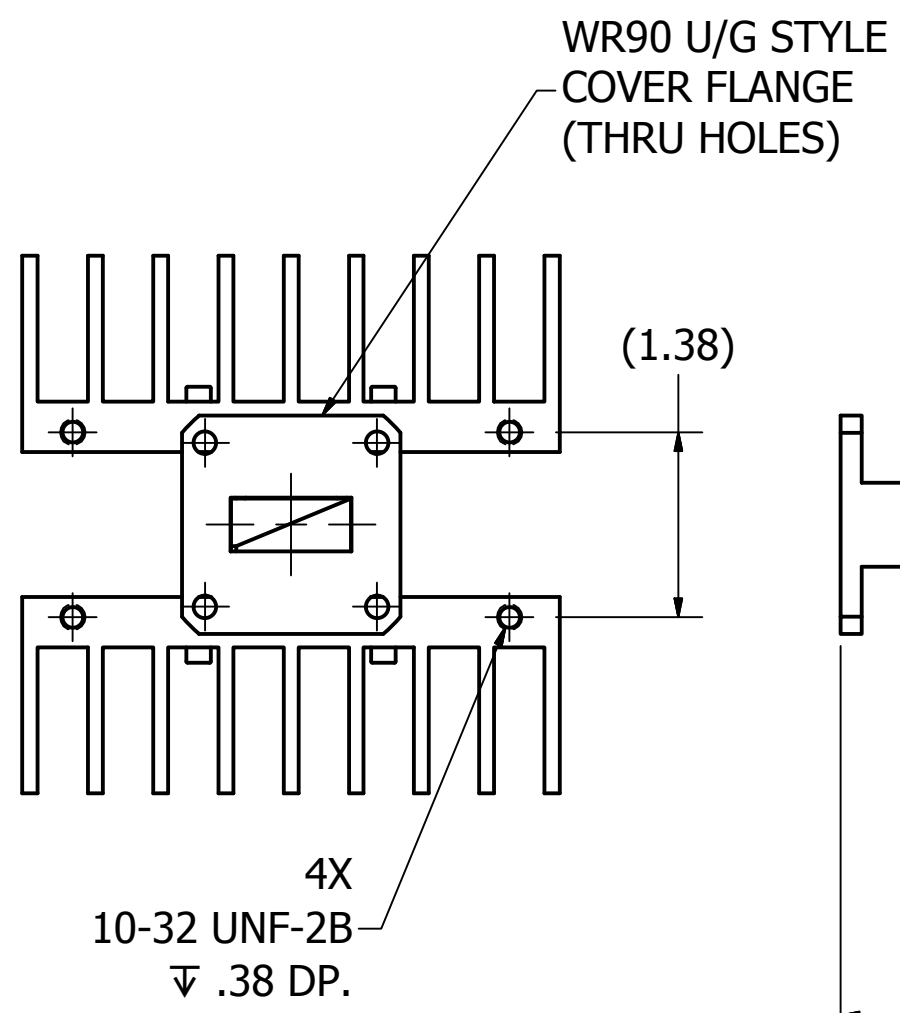
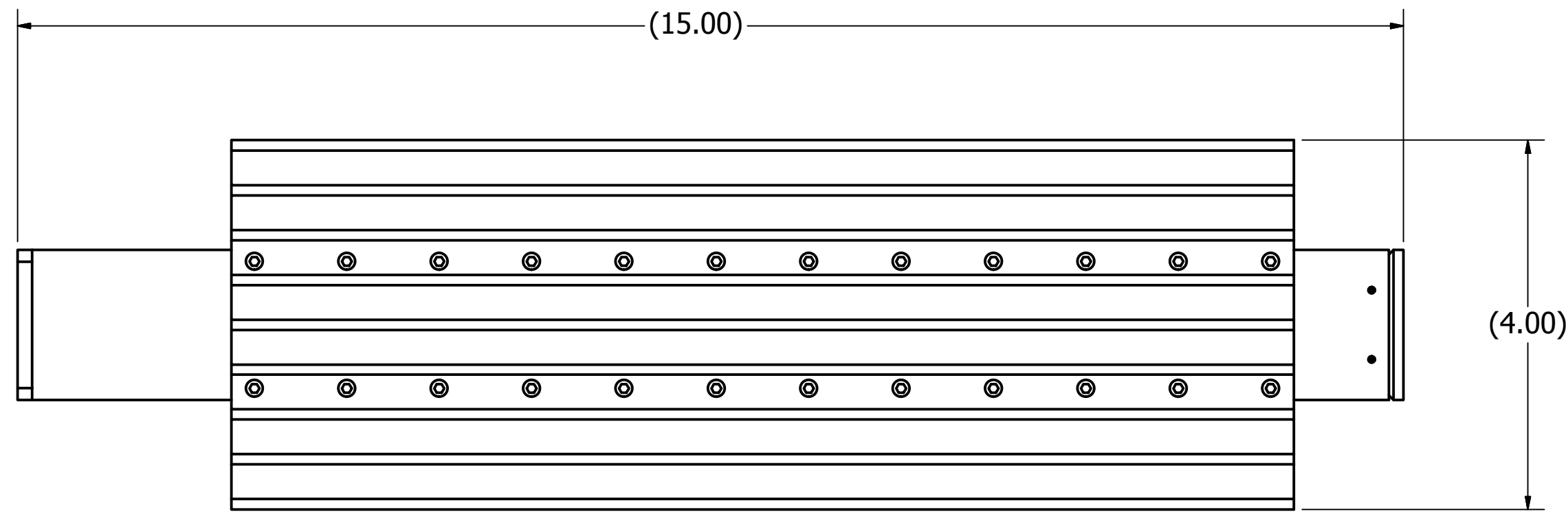

SPECIFICATIONS:

MODEL #: 90-780-6
W/G SIZE: WR90
INPUT FLANGE: U/G STYLE WR90, OTHERS AVAILABLE UPON REQUEST.
MATERIAL: ALUMINUM
FINISH: HI-TEMP BLACK

Released

USED ON: 90-780-6	QTY: 1	NEXT ASSY:	SHEET SIZE: C	THIRD ANGLE PROJECTION:	DRAWN: RL	DATE: 6/2/2018	 L3-NARDA-ATM 49 Rider Ave. Patchogue, NY 11772 TEL: (631) 289-0363 FAX: (631) 289-0358 www.atmicrowave.com CAGE CODE: OF8N4	THE INFORMATION ON THIS DRAWING IS PROPRIETARY. DISCLOSURE OR USE IS PERMITTED WITH THE PRIOR WRITTEN CONSENT OF L3 NARDA-ATM, INC. ONLY.
UNLESS OTHERWISE NOTED DIMENSIONS ARE IN INCHES. TOLERANCES ARE:			DECIMALS: ± 1/64 FRACTIONS: ± 1/64 2 PLACE: ± .005 3 PLACE: ± 1/2"		APPRVD.:	DATE:		MODEL # 90-780-6
SURFACE FINISH: .63 √ OR BETTER				FINISH: HI-TEMP BLACK	MATERIAL: ALUM	ATM DWG # 19501	OUTLINE, 90-780 TERMINATION	
							SHEET #: 1 of 1	