

REV	AUTH	DATE	INITIAL RELEASE
A	DM	06/26/12	INITIAL RELEASE
B	LM	7/11/14	CHANGE TOLERANCE OF 2 PLACE DECIMAL FROM: +/-0.01 TO: +/-0.02
C	DM	05/03/17	UPDATED TITLE BLOCK

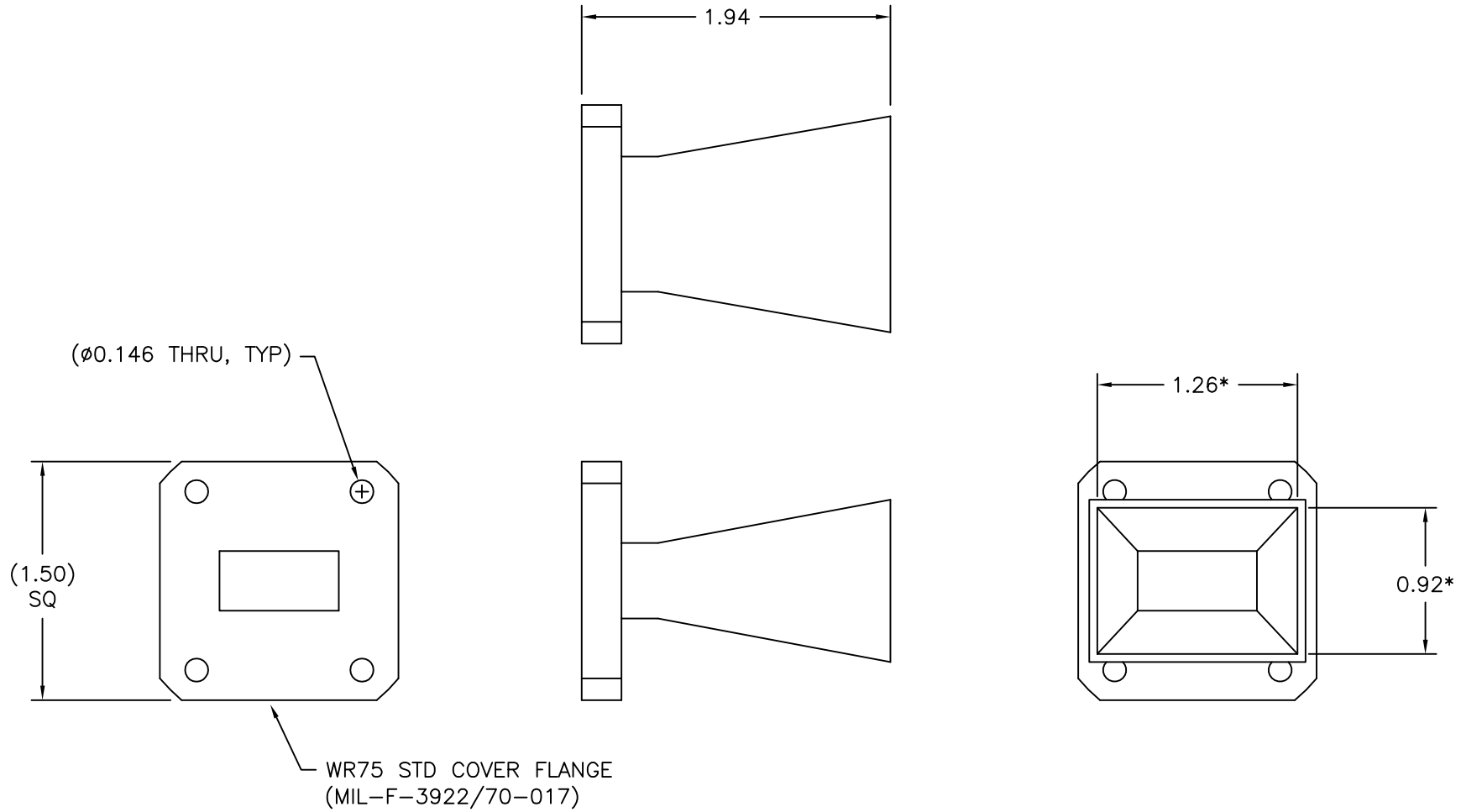

*INSIDE DIMENSION

***NOTE:** THESE DIMENSIONS ARE BASED ON THE FLANGE TYPE SHOWN ABOVE, AND MAY CHANGE WHEN OTHER FLANGE TYPES ARE SELECTED.

THIRD ANGLE PROJECTION:		APPROVALS	DATE			L-3 Narda - ATM TEL: (631) 289-0363 FAX: (631) 289-0358 www.atmmicrowave.com		THE INFORMATION IN THIS DRAWING IS PROPRIETARY AND SHALL NOT BE USED OR DISCLOSED WITHOUT THE PRIOR WRITTEN CONSENT OF ATM, INC. DO NOT SCALE DWG.	
UNLESS OTHERWISE NOTED, DIMENSIONS ARE IN INCHES, TOLERANCES ARE: FRACTIONS: $\pm 1/64$ ANGLES: $\pm 1/2^\circ$ MACHINED FINISH 63 \checkmark OR BETTER		DRAWN DM	05/02/17	OUTLINE WR75 HORN, 10dB GAIN		SIZE A CAGE CODE OR8N4 ATM DWG # 13967 REVISION C		SCALE NONE MODEL # 75-440-6 SHEET 1/1	
DECIMALS 2 PLACE 3 PLACE		CHKD.							
± 0.02 ± 0.005		APRVD.		MATERIAL ALUMINUM		TREATMENT _		FINISH CHEM FILM	