

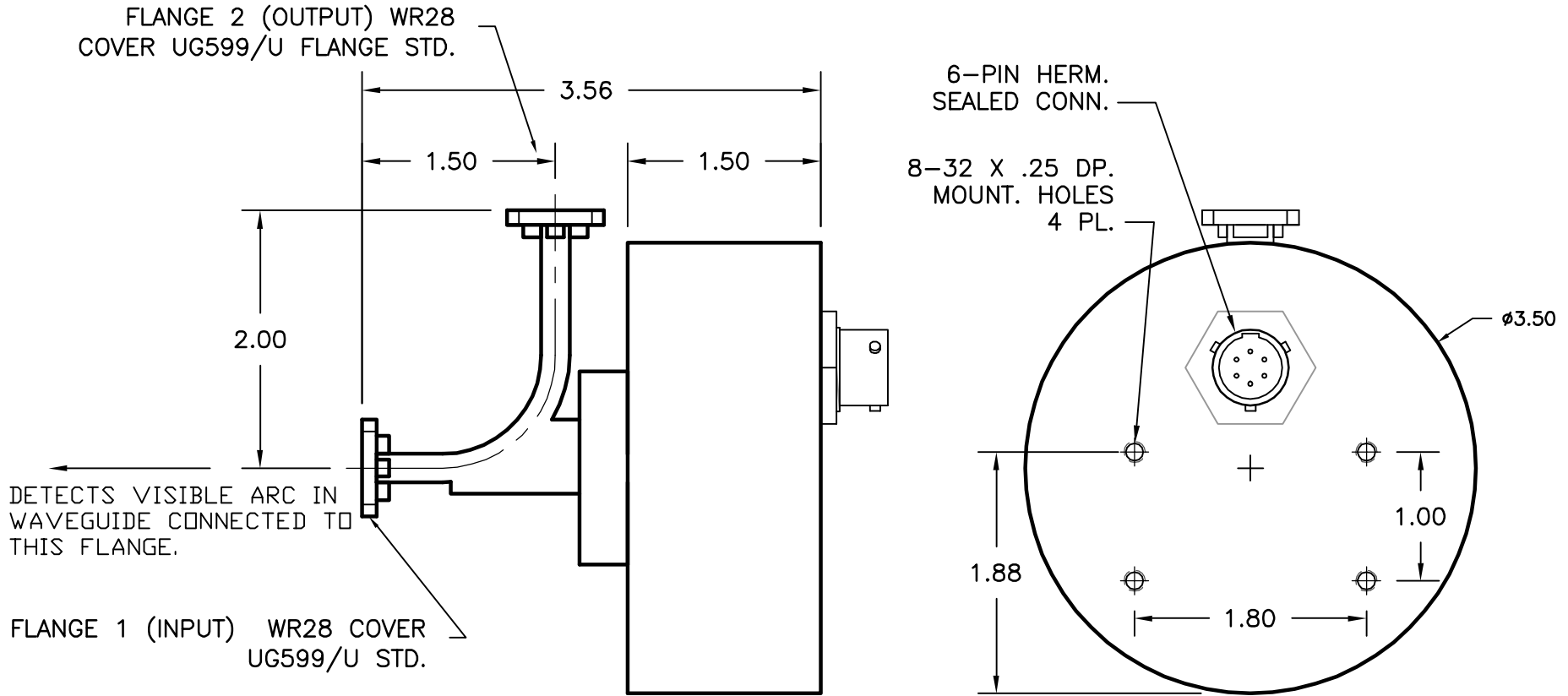
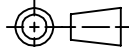

REV. A	DATE 6/7/02	INITIAL RELEASE	APPROVED
REV. B	DATE 8/13/04	UPDATED FORMAT, NOTES CLARIFY INPUT/OUTPUT FLANGES INPUT FLANGE (COVER) WAS CHOKE UG600A/U	APPROVED



MATERIAL -	TREATMENT -	DRAWN R. LYNCH	DATE 6/7/02
FINISH ATM GRAY	MOD NO. 2B-ARCE-X-X	CHECKED	DATE
OUTLINE, WR28 ARC DETECTOR		APPROVED	DATE
		<small>ADVANCED TECHNICAL MATERIALS, INC. 49 RIDER AVE., PATCHOGUE N.Y. 11772 TEL: (631) 289-0363 FAX: (631) 289-0358 http://www.atmmicrowave.com</small>	
<small>UNLESS OTHERWISE NOTED DIMENSIONS ARE IN INCHES</small>		<small>FRACTIONS ±1/64</small>	<small>DECIMALS ±.01</small>
<small>TOLERANCES ARE:</small>		<small>ANGLES ±1/2°</small>	<small>SHEET. 1/1</small>
 <small>PROPRIETARY NOTICE: THE INFORMATION IN THIS DRAWING IS PROPRIETARY AND SHALL NOT BE USED OR DISCLOSED WITHOUT THE PRIOR WRITTEN CONSENT OF ATM, INC.</small>		<small>SCALE 1 : 1</small>	<small>DWG. NO. 4992W</small>
			<small>REV. B</small>