

REV A	AUTH M.R.	DATE 12/12/16	INITIAL RELEASE
----------	--------------	------------------	-----------------

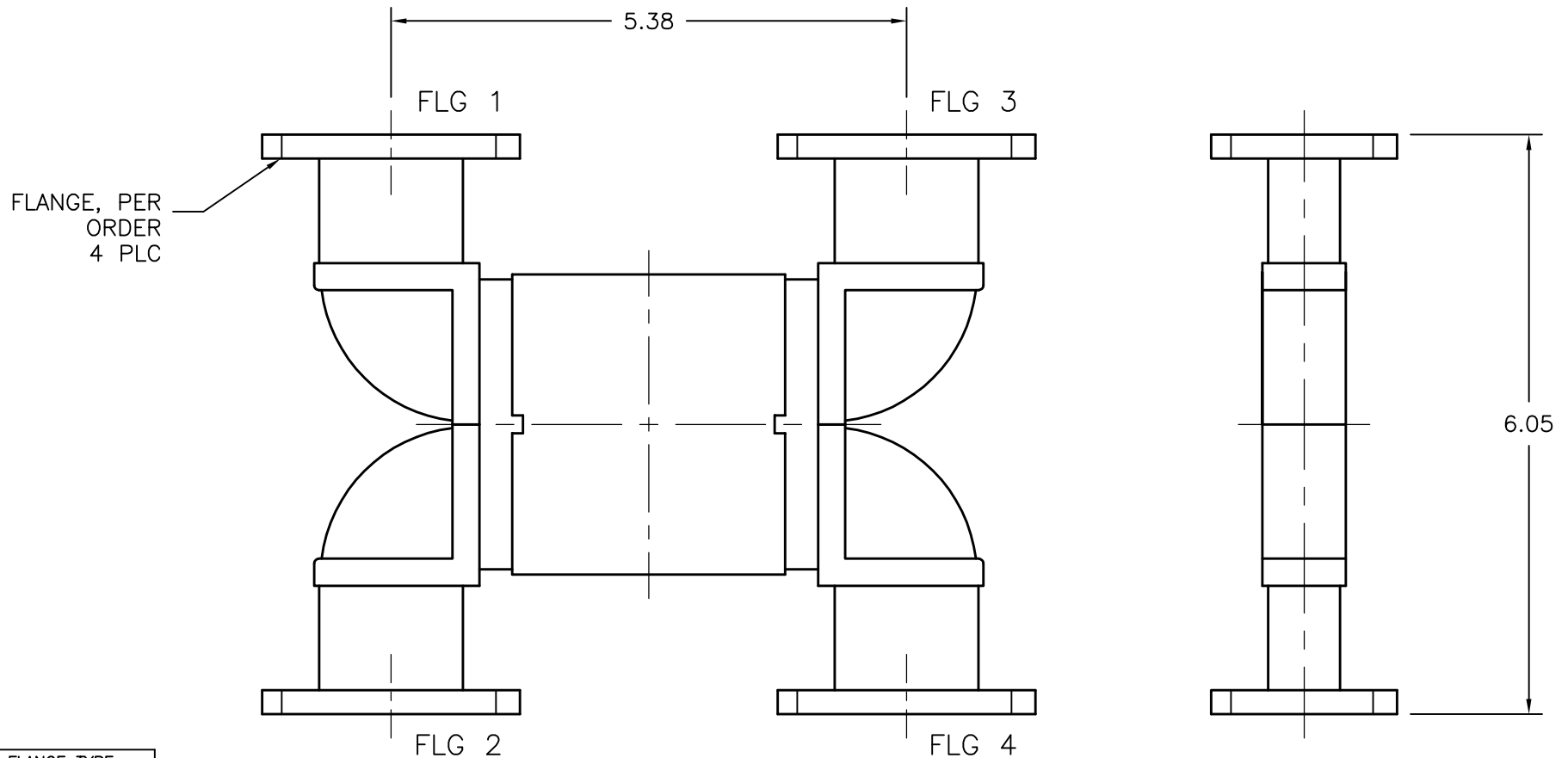

FLANGE TYPE
1 = CPRG
2 = CPRF
6 = UG COVER
7 = UG CHOKE
8 = COVER-GRV.

FREQUENCY	MODEL
5.40-6.00 GHz	137-261A-Y-F1-F2-F3-F4
5.80-6.50 GHz	137-265A-Y-F1-F2-F3-F4
6.00-7.00 GHz	137-262A-Y-F1-F2-F3-F4
6.85-7.80 GHz	137-263A-Y-F1-F2-F3-F4
7.15-8.20 GHz	137-264A-Y-F2-F2-F3-F4

NOTE: REPLACE "F1, F2, F3, & F4" NOTATION WITH NUMBER CORRESPONDING TO FLANGE TYPE DESIRED, AS SHOWN ON TABLE ABOVE.

THIRD ANGLE PROJECTION:		APPROVALS	DATE		L-3 Narda - ATM TEL: (631) 289-0363 FAX: (631) 289-0358 www.atmmicrowave.com		THE INFORMATION IN THIS DRAWING IS PROPRIETARY AND SHALL NOT BE USED OR DISCLOSED WITHOUT THE PRIOR WRITTEN CONSENT OF ATM, INC. DO NOT SCALE DWG.
UNLESS OTHERWISE NOTED, DIMENSIONS ARE IN INCHES, TOLERANCES ARE: FRACTIONS: $\pm 1/64$ ANGLES: $\pm 1/2^\circ$ MACHINED FINISH 63 $\checkmark$ OR BETTER		DRAWN M.R.	12/12/16		OUTLINE WR137 HYBRID COUPLER, "Y" TYPE		
DECIMALS 2 PLACE 3 PLACE		CHKD.		SIZE A	CAGE CODE OR8N4	ATM DWG # 18378	REVISION A
$\pm .02$	$\pm .010$	APRVD.		SCALE 1 : 1	MODEL # SEE TABLE	SHEET 1/1	
		MATERIAL PER ORDER					
		TREATMENT CHEM FILM					
		ATM STD GRAY					