

NOTES: UNLESS OTHERWISE SPECIFIED:

**MECHANICAL:**

DIMENSIONS PER DRAWING.

MATERIAL: ALUMINUM ALLOY.

FINISH: CHEMICAL FILM

CONNECTORS: TYPE K FEMALE 2 REQD.

**ELECTRICAL:**

VSWR: 1.5:1 MAX

PHASE SHIFT: 0-360°

INSERTION LOSS: 1.3 dB± 1 MAX THRU RANGE

APPLICATION	
FREQUENCY	MODEL #
26.0-30.0	P28K-410
27.5-31.2	P28K-414
30.0-31.0	P28K-415
30.0-34.0	P28K-411
33.5-37.0	P28K-412
36.0-40.0	P28K-413

REVISION HISTORY			
REV	AUTH	DATE	DESCRIPTION
A	BF	8-18-11	INITIAL RELEASE
B	RL	7-26-16	MODELS REVISED: -416 ADDED.

ADJUSTMENT W/ SLOTTED SHAFT AND LOCKNUT PROVIDED

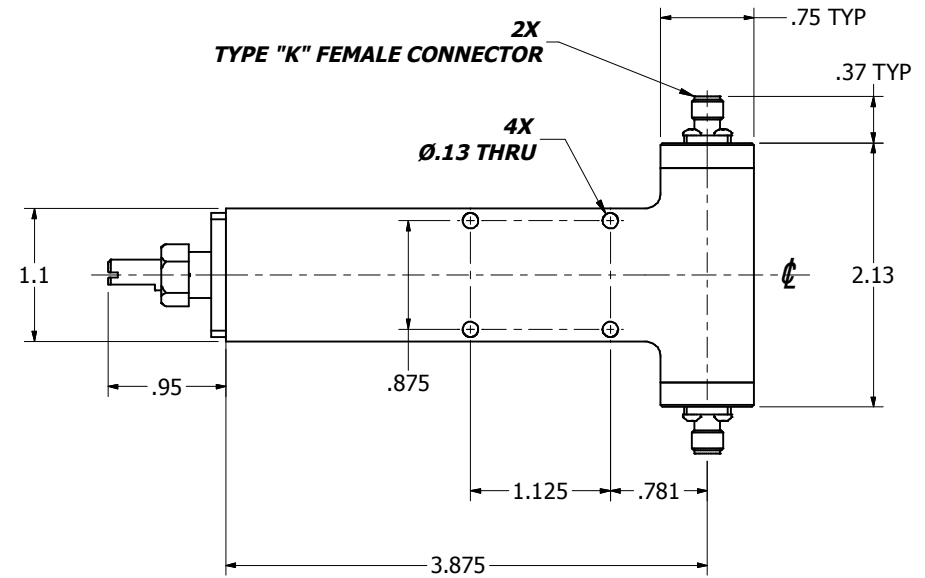
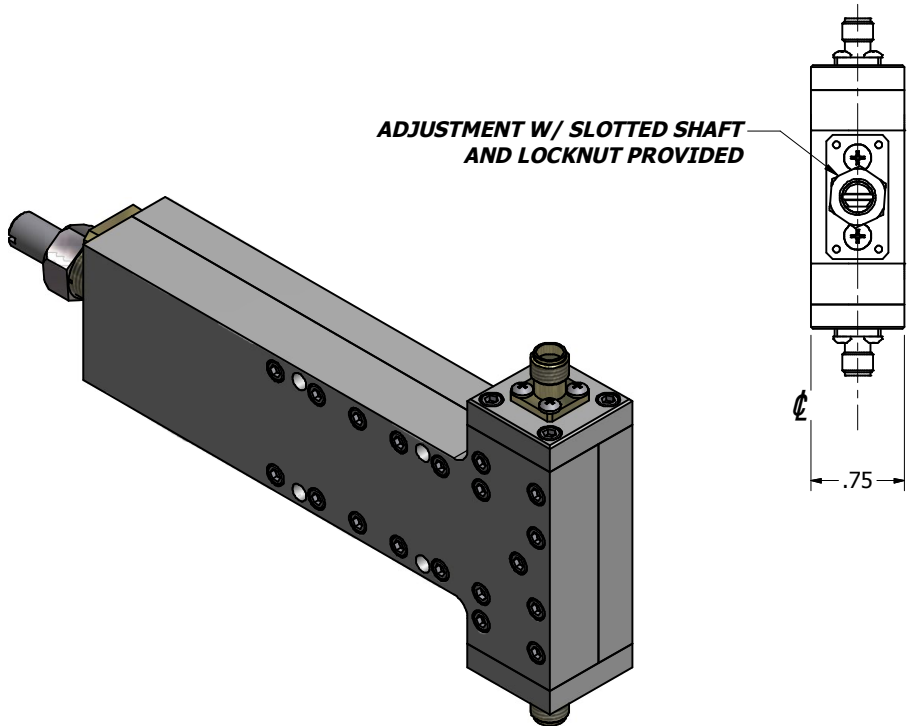

USED ON:	QTY:	NEXT ASSY:	THIRD ANGLE PROJECTION:	DRAWN: BF	DATE: 8-18-11	 <b>L3-NARDA-ATM</b> 49 Rider Ave, Patchogue, NY 11772 TEL: (631) 289-0363 FAX: (631) 289-0358 www.atmicrowave.com CAGE CODE: 08R84	<small>THE INFORMATION IN THIS DRAWING IS PROPRIETARY AND SHALL NOT BE USED OR REPRODUCED WITHOUT THE PRIOR WRITTEN CONSENT OF L3 NARDA-ATM, INC.</small>		
			<small>UNLESS OTHERWISE NOTED, DIMENSIONS ARE IN INCHES. TOLERANCES ARE: FRACTIONS: ±1/64 ° ANGLES: ±1/2°</small>	CHKD:					
			<small>DECIMALS: 2 PLACE 3 PLACE</small>	MATERIAL:	SEE NOTES	<b>OUTLINE,</b> <b>COAXIAL PHASE SHIFTER</b>	<small>MODEL # P28K-XXX</small>		
			<small>±.01 ±.005</small>	TREATMENT:				<b>13383</b>	<small>REVISION B</small>
			<small>SHEET SIZE: B</small>	FINISH:	SEE NOTES				
			<small>SHEET #: 1 OF 1</small>	SURFACE FINISH:	63 √ OR BETTER				