

REV A	AUTH M.R.	DATE 04/28/17	INITIAL RELEASE
----------	--------------	------------------	-----------------

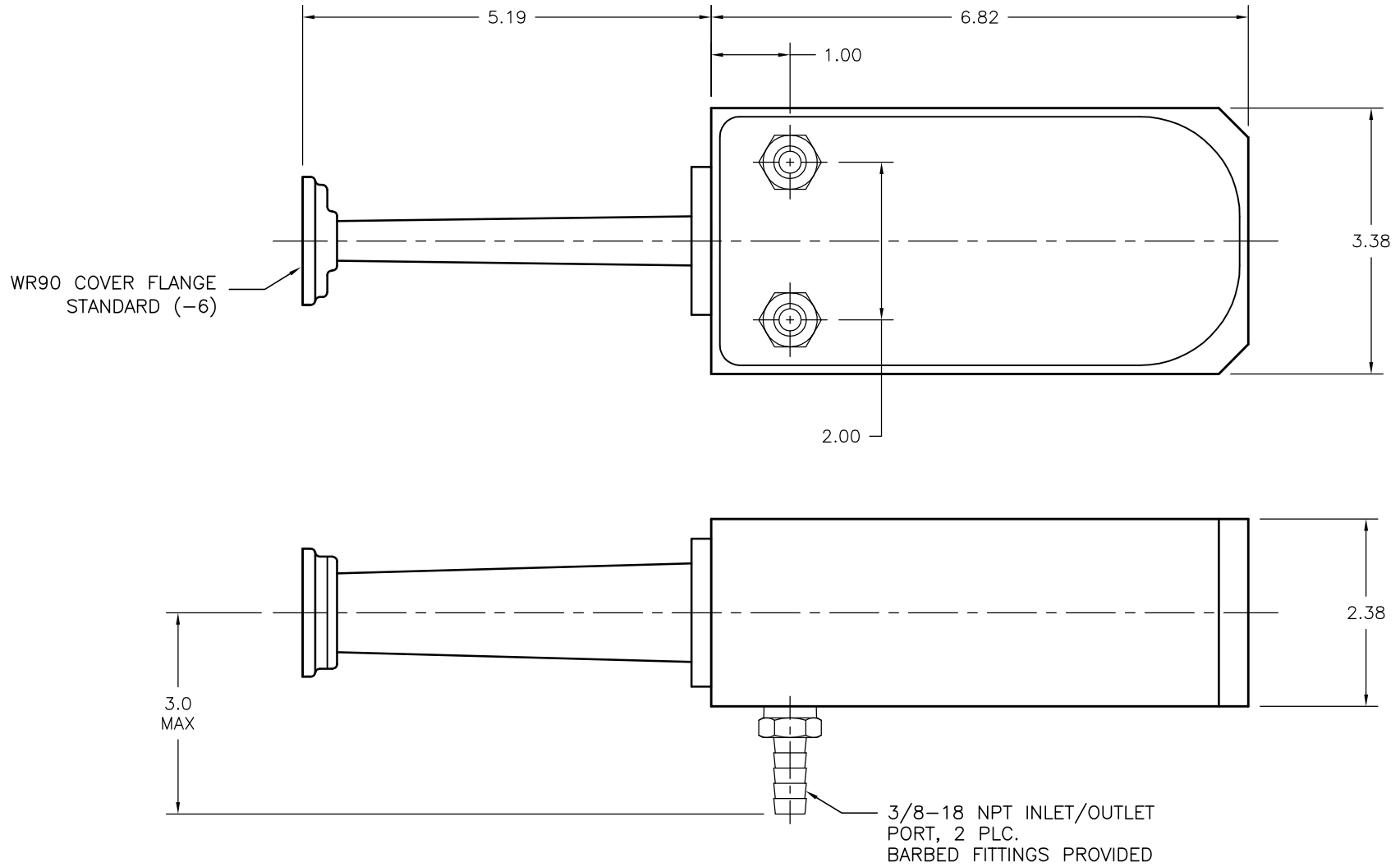

THIRD ANGLE PROJECTION		APPROVALS		DATE	L-3 Narda - ATM		THE INFORMATION IN THIS DRAWING IS PROPRIETARY AND SHALL NOT BE USED OR DISCLOSED WITHOUT THE PRIOR WRITTEN CONSENT OF L3 NARDA-ATM, INC. DO NOT SCALE DWG.	
UNLESS OTHERWISE NOTED, DIMENSIONS ARE IN INCHES, TOLERANCES ARE:  FRACTIONS: $\pm 1/64$ ANGLES: $\pm 1/2^\circ$  MACHINED FINISH 63 $\checkmark$ OR BETTER		DRAWN M.R.		04/28/17	 narda ATM TEL: (631) 289-0363 FAX: (631) 289-0358 www.atmmicrowave.com		<b>OUTLINE</b> <b>WR90 WATERCOOLED TERMINATION</b>	
		CHKD.						
		APRVD.						
DECIMALS 2 PLACE 3 PLACE		MATERIAL ALUM BODY		SIZE A	CAGE CODE OR8N4	ATM DWG # 18660	REVISION A	
$\pm .02$ $\pm .005$		TREATMENT -		SCALE 1 : 1	MODEL # 90-770-6	SHEET 1/1		
		CHEM FILM						