

2

1

REVISION HISTORY

REV	AUTH	DATE	DESCRIPTION
A	BF	10-22-13	INITIAL RELEASE
B	BF	2-4-14	ADD "MAX" TO 10.63 DIMENSION

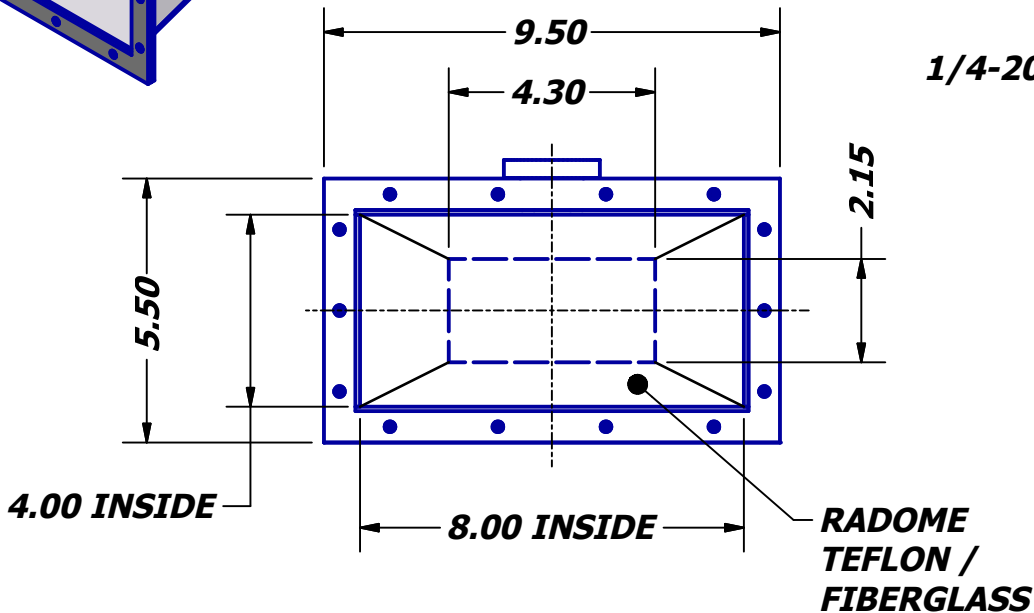
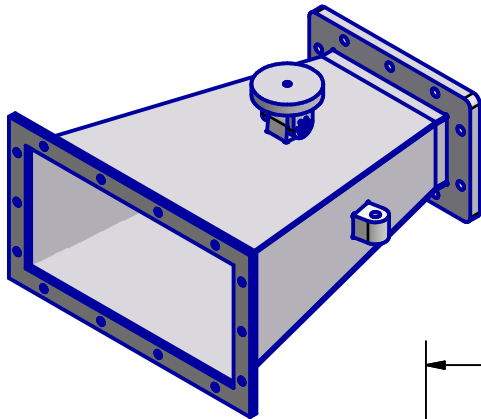

**SWIVEL
MTG BRACKET
1/4-20 MTG HARDWARE**

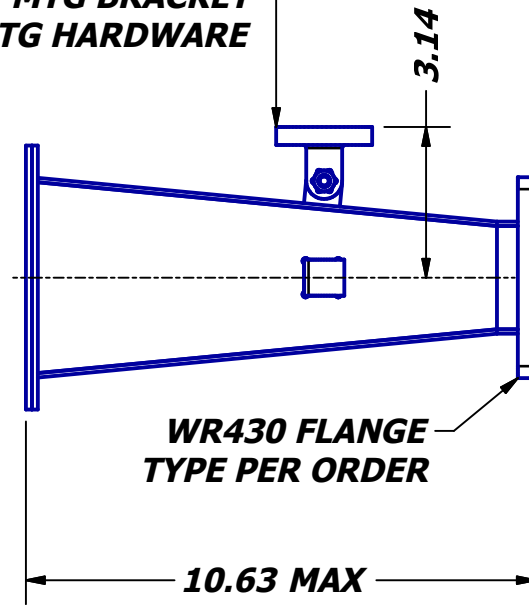

B

NOTES:
1. FREQ GHz: 1.70 - 2.60
GAIN: 10dB

MODEL NO	QTY	NEXT ASSY	THIRD ANGLE PROJECTION:	APPROVALS	DATE		ADVANCED TECHNICAL MATERIALS, INC.		THE INFORMATION IN THIS DRAWING IS PROPRIETARY AND SHALL NOT BE USED OR DISCLOSED WITHOUT THE PRIOR WRITTEN CONSENT OF ATM, INC. DO NOT SCALE DWG.
			UNLESS OTHERWISE NOTED, DIMENSIONS ARE IN INCHES, TOLERANCES ARE: FRACTIONS: ±1/64 ANGLES: ±1/2°	DRAWN BF	10-22-13		TEL: (631) 289-0363 FAX: (631) 289-0358	www.atmmicrowave.com	
			DECIMALS 2 PLACE 3 PLACE	CHKD.		OUTLINE, WR430 HORN ANTENNA			
			±.01 ±.005	APRVD.					
			MACHINED FINISH 63 ✓ OR BETTER	MATERIAL ALUMNUM		SIZE A	CAGE CODE 0R8N4	ATM DWG # 15439	REVISION B
				TREATMENT IRIDITE		MODEL #	430-440-2/RD/BR		SHEET 1 OF 1
				FINISH ATM STD GRAY					

2

1