

REV A	AUTH D.M.	DATE 07/03/12	INITIAL RELEASE
B	M.R.	12/06/16	NO DIMENSIONAL CHANGES. FORMAT UPDATE
C	DM	05/03/17	UPDATED TITLE BLOCK

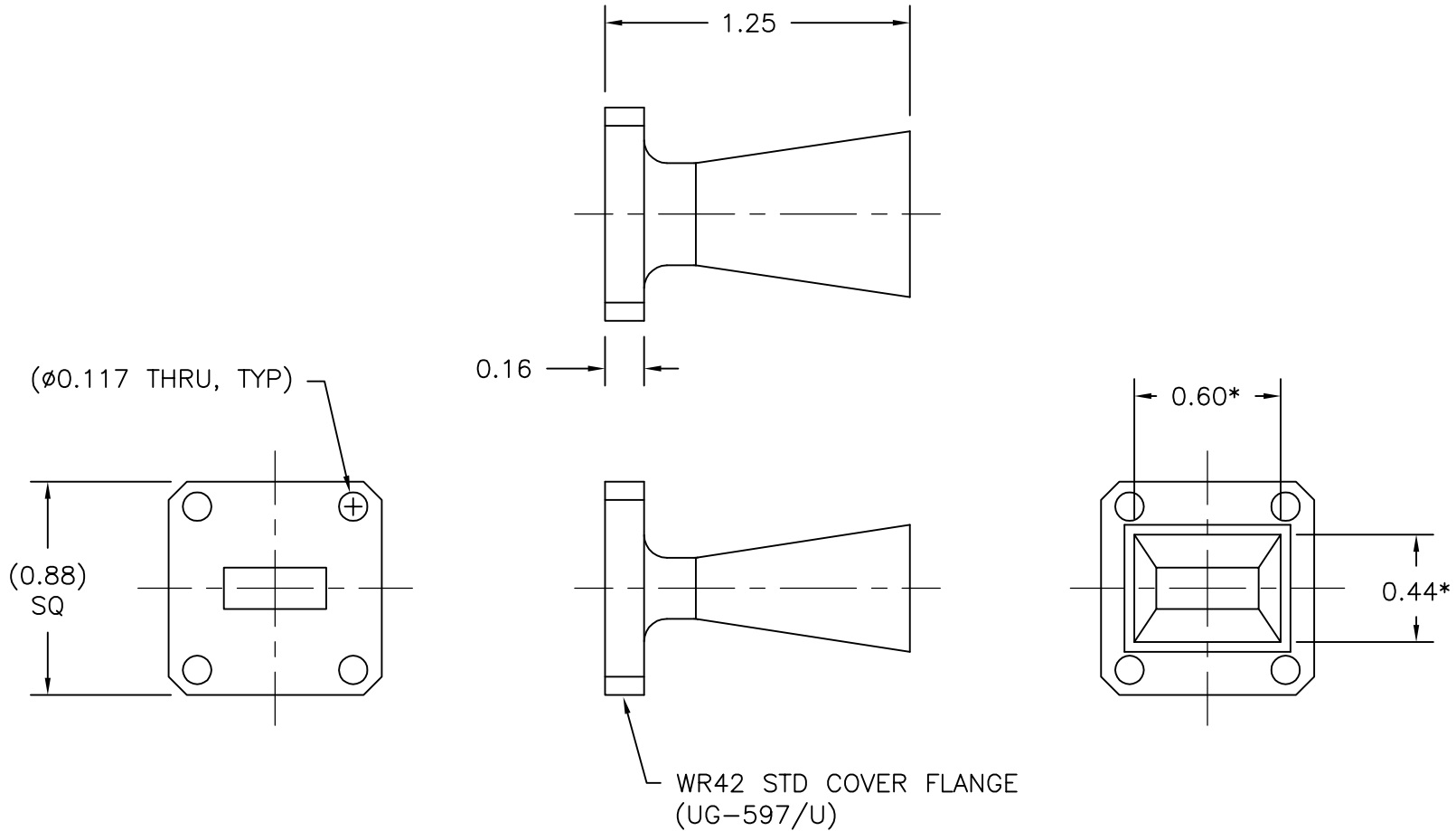

\*INSIDE DIMENSION

\*NOTE: THESE DIMENSIONS ARE BASED ON THE FLANGE TYPE SHOWN ABOVE, AND MAY CHANGE WHEN OTHER FLANGE TYPES ARE SELECTED.

THIRD ANGLE PROJECTION:		APPROVALS		DATE	 <b>L-3 Narda - ATM</b> TEL: (631) 289-0363 FAX: (631) 289-0358 www.atmmicrowave.com	THE INFORMATION IN THIS DRAWING IS PROPRIETARY AND SHALL NOT BE USED OR DISCLOSED WITHOUT THE PRIOR WRITTEN CONSENT OF ATM, INC. DO NOT SCALE DWG.					
UNLESS OTHERWISE NOTED, DIMENSIONS ARE IN INCHES, TOLERANCES ARE:  FRACTIONS: $\pm 1/64$ ANGLES: $\pm 1/2^\circ$  MACHINED FINISH 63 $\sqrt{\text{OR BETTER}}$		DRAWN	D.M.	07/03/12							
		CHKD.									
DECIMALS 2 PLACE    3 PLACE  $\pm .01$ $\pm .005$		APRVD.			<b>OUTLINE</b> WR42 HORN - 10dB		REVISION	C			
		MATERIAL	6061 ALUM.				SIZE	A	CAGE CODE	OR8N4	ATM DWG #
		TREATMENT	CHEM FILM		SCALE	NONE		MODEL #	42-440-6	SHEET	1/1
		FINISH									