

REV A	AUTH D.M.	DATE 07/03/12	INITIAL RELEASE
REV B	AUTH M.R.	DATE 12/06/16	NO DIMENSIONAL CHANGES. FORMAT UPDATE

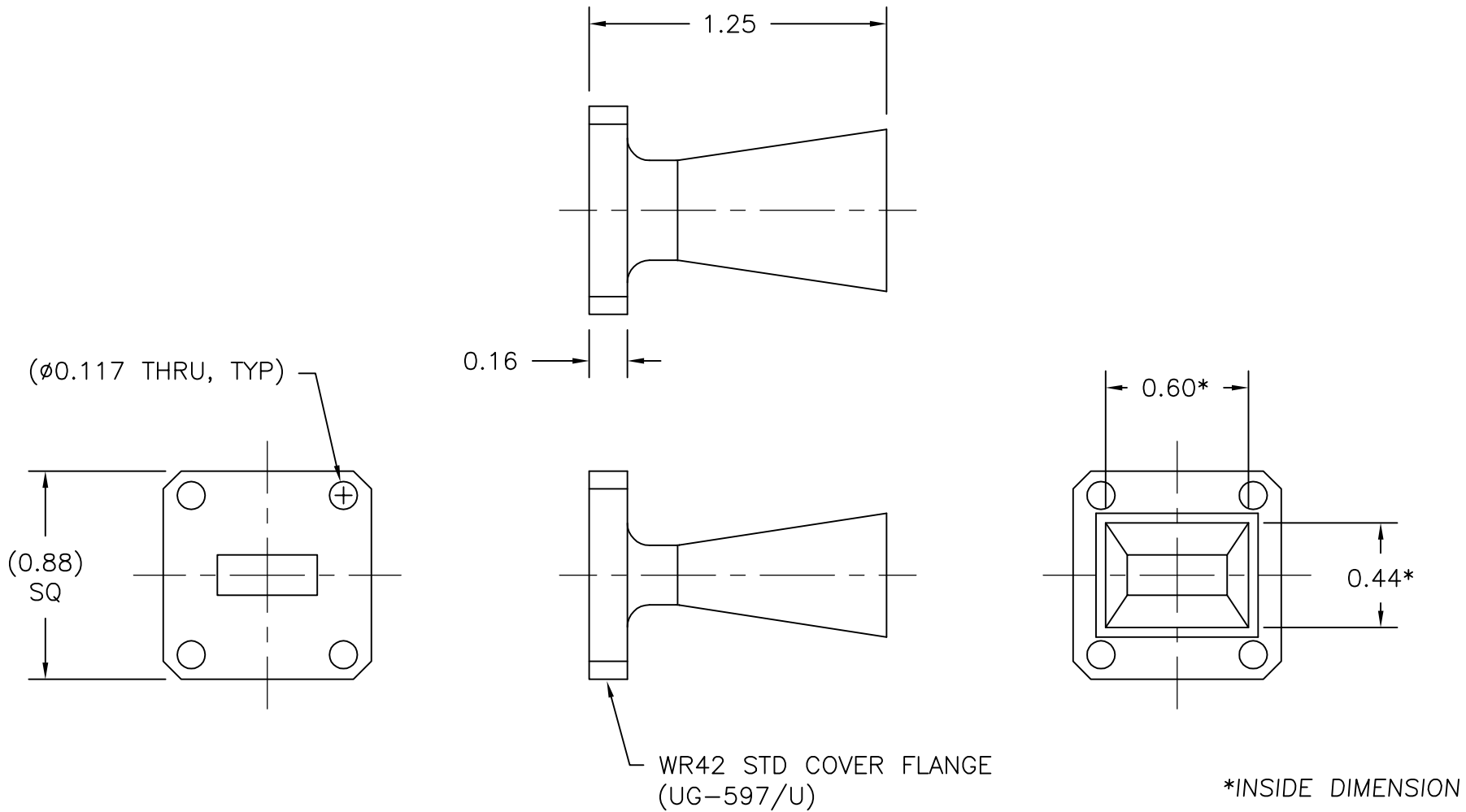

THIRD ANGLE PROJECTION:		APPROVALS		DATE	 L-3 Narda - ATM TEL: (631) 289-0363 FAX: (631) 289-0358 www.atmmicrowave.com	THE INFORMATION IN THIS DRAWING IS PROPRIETARY AND SHALL NOT BE USED OR DISCLOSED WITHOUT THE PRIOR WRITTEN CONSENT OF ATM, INC. DO NOT SCALE DWG.	
UNLESS OTHERWISE NOTED, DIMENSIONS ARE IN INCHES, TOLERANCES ARE: FRACTIONS: ±1/64 ANGLES: ±1/2° MACHINED FINISH 63 ✓ OR BETTER		DRAWN D.M.		07/03/12			
		CHKD.			OUTLINE WR42 HORN - 10dB		
		APRVD.					
DECIMALS 2 PLACE 3 PLACE		MATERIAL 6061 ALUM.		SIZE A	CAGE CODE OR8N4	ATM DWG # 13958	REVISION B
±.01	±.005	TREATMENT CHEM FILM		SCALE 1 : 1	MODEL # 42-440-6	SHEET 1/1	