

REV A	AUTH M.R.	DATE 7/24/09	INITIAL RELEASE
REV B	AUTH M.R.	DATE 04/16/12	MODEL# UPDATED, WAS 28-124RA-X-X-X

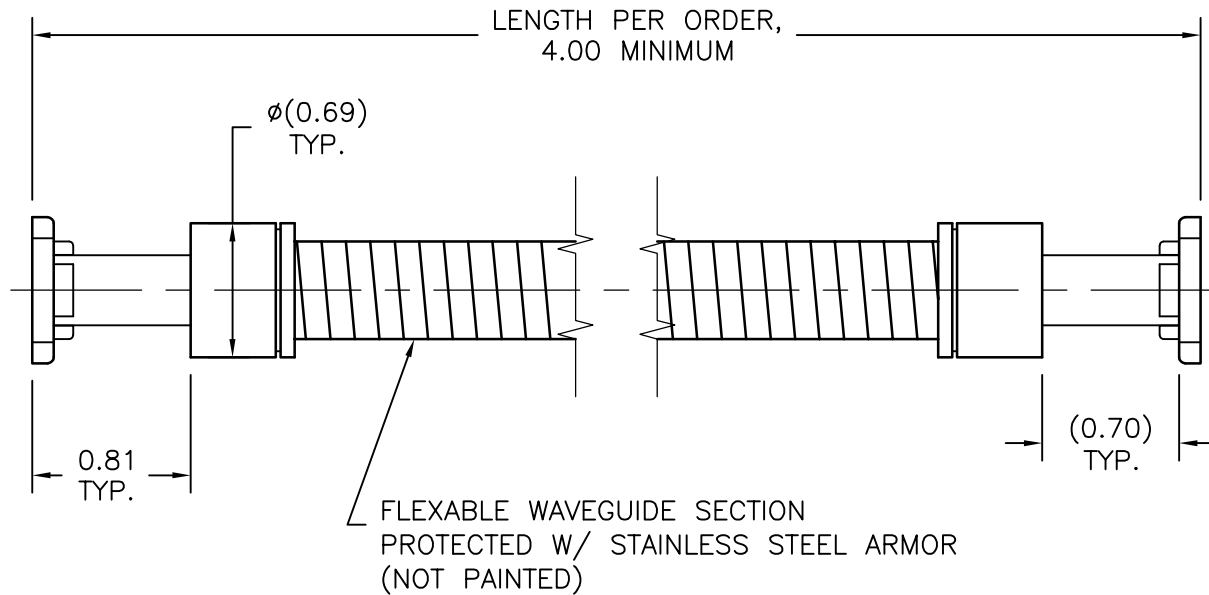

MODEL SPECIFICATIONS

MECHANICAL

MODEL NUMBER: 28-126-(L)-X-X

MATERIAL:

WAVEGUIDE/FLANGES: BRASS/COPPER
ARMORED SECTION: STAINLESS STEEL

FINISH:

WAVEGUIDE SECTIONS: UNIQUE CORROSION RESISTANT
316 STAINLESS STEEL EPOXY COATING
NO PAINT
ARMORED SECTION:
FLANGES: PER ORDER, COVER TYPE STANDARD

THIRD ANGLE PROJECTION:		APPROVALS	DATE	ADVANCED TECHNICAL MATERIALS, INC. TEL: (631) 289-0363 FAX: (631) 289-0358 www.atmmicrowave.com		<small>THE INFORMATION IN THIS DRAWING IS PROPRIETARY AND SHALL NOT BE USED OR DISCLOSED WITHOUT THE PRIOR WRITTEN CONSENT OF AT&T, INC. DO NOT SCALE DWG.</small>			
UNLESS OTHERWISE NOTED, DIMENSIONS ARE IN INCHES, TOLERANCES ARE: FRACTIONS: $\pm 1/64$ ANGLES: $\pm 1/2^\circ$		DRAWN M.R.	07/24/09						
		BASIC DIMENSION		DECIMALS 2 PLACE	DECIMALS 3 PLACE	CHKD.	APRVD.	FLEX WAVEGUIDE ASSEM WITH ARMORED SECTION	
UNDER 6"	$\pm .02$	$\pm .005$	MATERIAL PER ORDER	SIZE A	CAGE CODE OR8N4	ATM DWG # 9938	REVISION B		
6" - 12"	$\pm .03$	$\pm .010$	TREATMENT CHEM FILM	SCALE 1 : 1	MODEL # 28-126-(L)-X-X	SHEET 1/1			
OVER 12"	$\pm .06$	$\pm .015$	FINISH SEE NOTES						