

REVISION HISTORY			
REV	AUTH	DATE	DESCRIPTION
-	RL	07/21/06	INITIAL RELEASE
A	MR	07/27/11	PAINT CHANGED TO OPTIONAL
B	DM	09/16/11	UPDATED TO INVENTOR PROGRAM

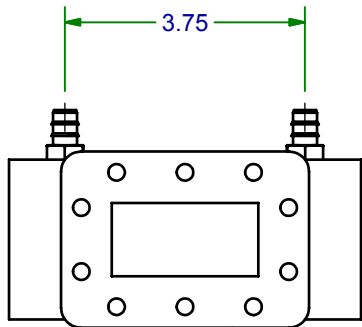
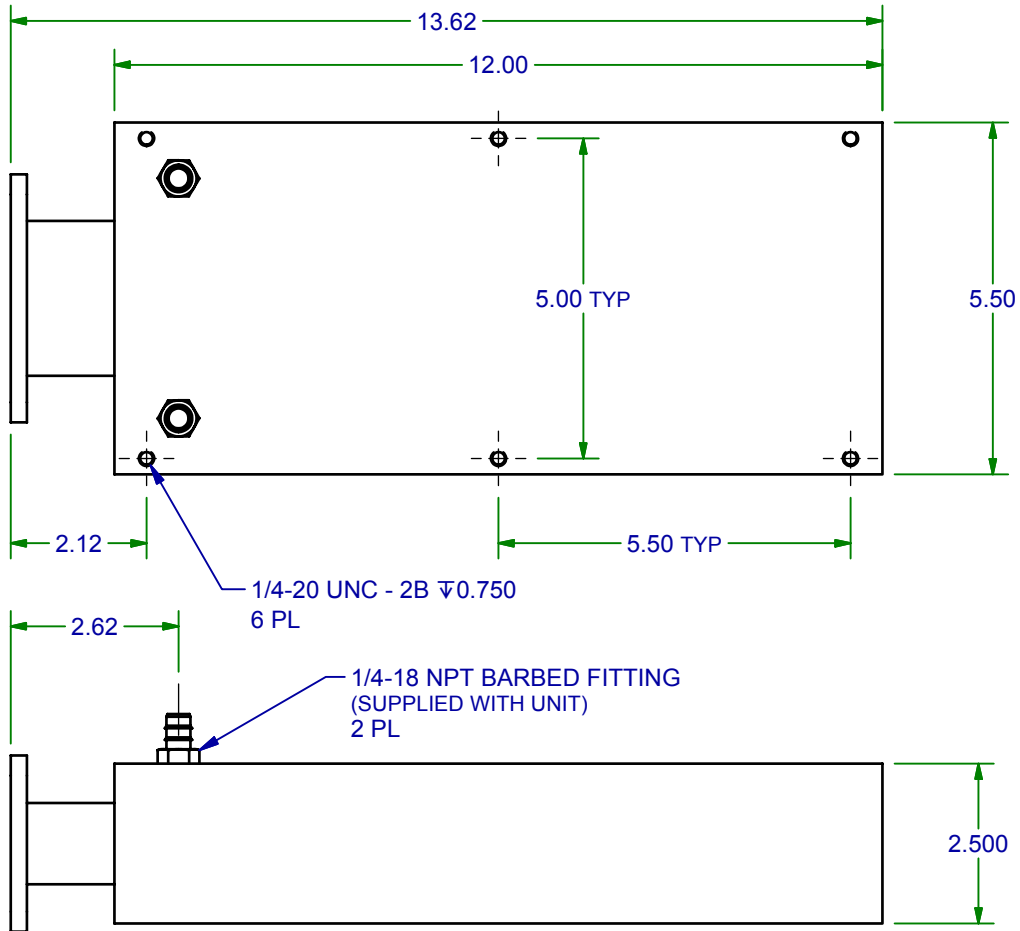
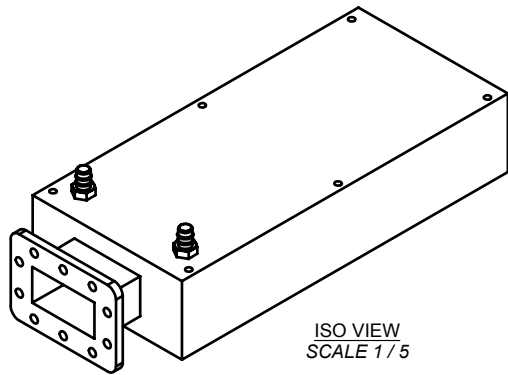

NOTE:
1. SHOWN WITH CPRF FLANGE.

MODEL SPECIFICATIONS:

MECHANICAL
 MODEL NUMBER: 229-770-1200W-X
 MATERIAL: 6061-T6 ALUMINUM
 FINISH: CHEM FILM (HI-TEMP BLACK OPTIONAL)
 FLANGES: PER ORDER (CPR229F STANDARD)

ELECTRICAL
 FREQ RANGE: 3.3 - 4.9 GHz
 POWER: 1200 WATTS

THIRD ANGLE PROJECTION:		APPROVALS	DATE	ADVANCED TECHNICAL MATERIALS, INC. TEL: (631) 289-0363 FAX: (631) 289-0358 www.atmmicrowave.com	THE INFORMATION IN THIS DRAWING IS PROPRIETARY AND SHALL NOT BE USED OR DISCLOSED WITHOUT THE PRIOR WRITTEN CONSENT OF ATM, INC. DO NOT SCALE DWG.
UNLESS OTHERWISE NOTED, DIMENSIONS ARE IN INCHES. TOLERANCES ARE: FRACTIONS: $\pm 1/64$ ANGLES: $\pm 1/2^\circ$		DRAWN DM			
DECIMALS		CHKD.		OUTLINE WR229 "770" TERMINATION	
2 PLACE	3 PLACE	APRVD.			
± 01	± 005	MATERIAL ALUMINUM		SIZE A	REVISION B
		TREATMENT -		CAGE CODE 0R8N4	ATM DWG # 6846
		FINISH CHEM FILM		MODEL # 229-770-1200W-X	SHEET 1/1