

2

1

REVISION HISTORY			
REV	AUTH	DATE	DESCRIPTION
A	BF	11/23/2009	INITIAL RELEASE

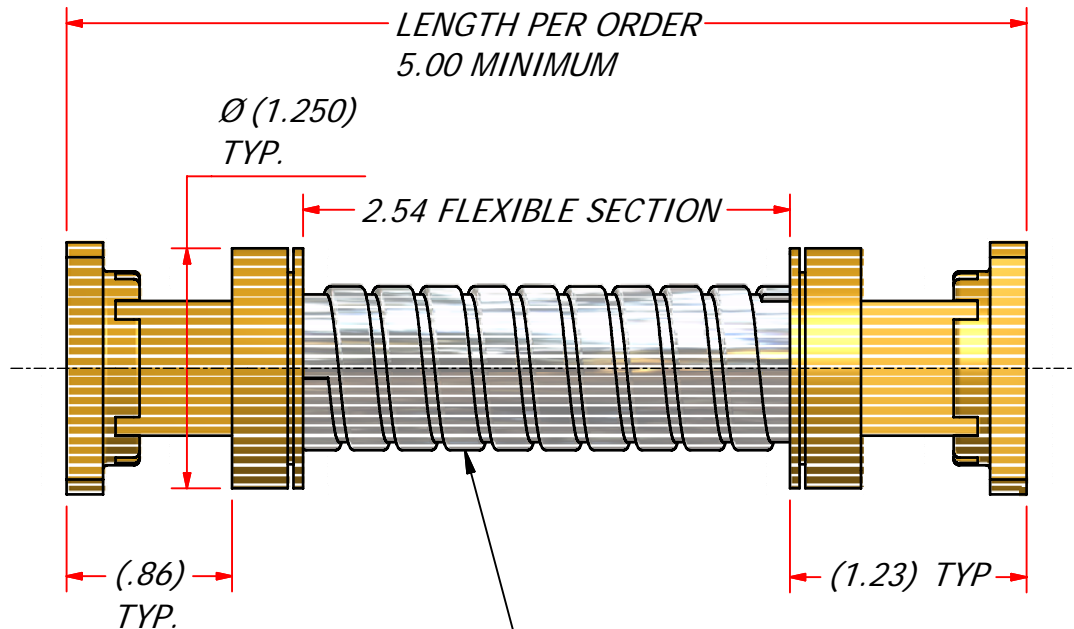

MODEL SPECIFICATIONS

MECHANICAL

MODEL NUMBER: 62-126RA-X-X-X

MATERIAL:

WAVEGUIDE/ FLANGES: BRASS/ COPPER

ARMORED SECTION: STAINLESS STEEL

FINISH:

WAVEGUIDE SECTIONS: UNIQUE CORROSION RESISTANT
316 STAINLESS STEEL EPOXY COATING

ARMORED SECTION:

NO PAINT

FLANGES:

PER ORDER, COVER TYPE STANDARD

FLEXIBLE WAVEGUIDE SECTION
PROTECTED W/ STAINLESS STEEL ARMOR
(NOT PAINTED)

MODEL USED ON	QTY	NEXT ASSY	THIRD ANGLE PROJECTION:		APPROVALS	DATE	ADVANCED TECHNICAL MATERIALS, INC. TEL: (631) 289-0363 FAX: (631) 289-0358 www.atmmicrowave.com			THE INFORMATION IN THIS DRAWING IS PROPRIETARY AND SHALL NOT BE USED OR DISCLOSED WITHOUT THE PRIOR WRITTEN CONSENT OF ATM, INC. DO NOT SCALE DWG.	
			UNLESS OTHERWISE NOTED, DIMENSIONS ARE IN INCHES, TOLERANCES ARE:		DRAWN BF	11-23-09					
			FRACTIONS: ±1/64 ANGLES: ±1/2°		CHKD.						
			BASIC DIMENSION	DECIMALS 2 PLACE	DECIMALS 3 PLACE	APRVD.					
			UNDER 6"	±.02	±.005	MATERIAL PER ORDER	SIZE A	CAGE CODE 0R8N4	ATM DWG # 11821	REVISION A	
			6" - 12"	±.03	±.010	TREATMENT CHEM FILM	MODEL # 62-126RA-X-X-X			SHEET 1 OF 1	
			OVER 12"	±.06	±.015	FINISH SEE NOTES					

2

1