

REV A	AUTH D.M.	DATE 07/11/12	INITIAL RELEASE
B	L.M.	07/11/14	CHANGE TOLERANCE OF 2 PLACE DECIMAL FROM: +/- .01 TO: +/- .03
C	M.R.	12/06/16	UPDATED FLANGE ILLUSTRATION, NO DIMENSIONAL CHANGES. FORMAT UPDATE.
D	DM	05/02/17	UPDATED TITLE BLOCK ; NO DIMENSIONAL CHANGES

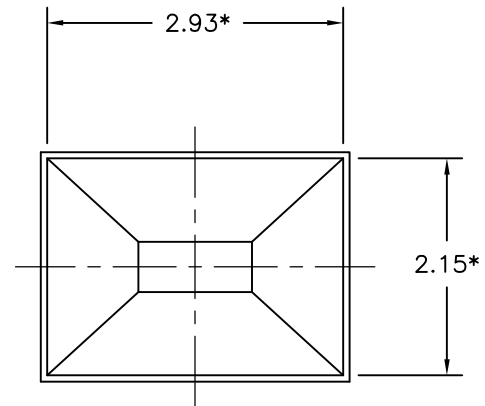
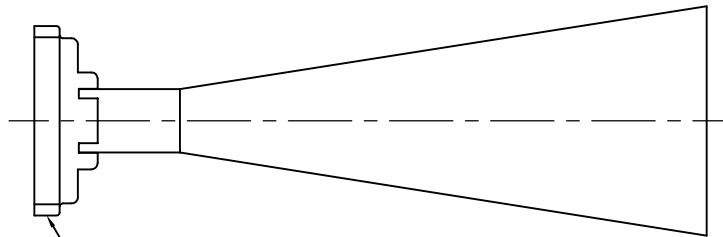
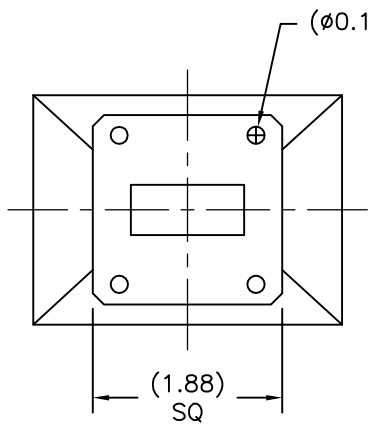
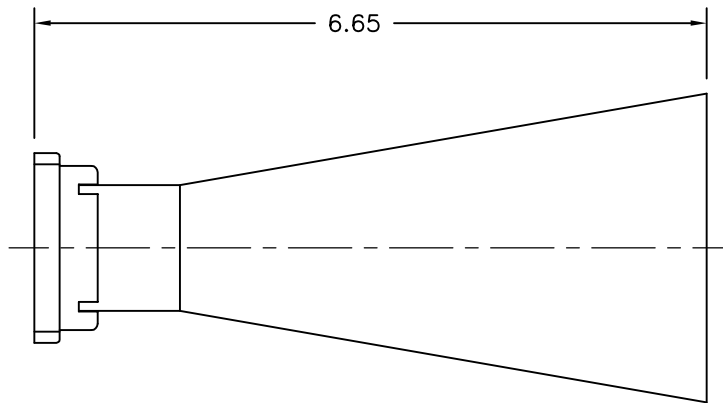

*INSIDE DIMENSION

*NOTE: THESE DIMENSIONS ARE BASED ON THE FLANGE TYPE SHOWN ABOVE, AND MAY CHANGE WHEN OTHER FLANGE TYPES ARE SELECTED.

THIRD ANGLE PROJECTION:		APPROVALS		DATE		L-3 Narda - ATM		THE INFORMATION IN THIS DRAWING IS PROPRIETARY AND SHALL NOT BE USED OR DISCLOSED WITHOUT THE PRIOR WRITTEN CONSENT OF ATM, INC. DO NOT SCALE DWG.
UNLESS OTHERWISE NOTED, DIMENSIONS ARE IN INCHES, TOLERANCES ARE: FRACTIONS: ±1/64 ANGLES: ±1/2° MACHINED FINISH 63 ✓ OR BETTER		DRAWN D.M.		05/02/17		TEL: (631) 289-0363 FAX: (631) 289-0358 www.atmmicrowave.com		
DECIMALS 2 PLACE 3 PLACE		CHKD.			OUTLINE WR112 HORN - 15dB			REVISION
±.03	±.005	APRVD.						SIZE A
		MATERIAL ALUM ALLOY			SCALE	MODEL #	112-441-6	SHEET 1/1
		TREATMENT CHEM FILM						
		FINISH						