

REV A	AUTH D.M.	DATE 07/03/12	INITIAL RELEASE
REV B	AUTH L.M.	DATE 07/11/14	CHANGE TOLERANCE OF 2 PLACE DECIMAL FROM: +/-0.01 TO: +/-0.03
REV C	AUTH M.R.	DATE 12/06/16	UPDATED FLANGE ILLUSTRATION, NO DIMENSIONAL CHANGES. FORMAT UPDATE.

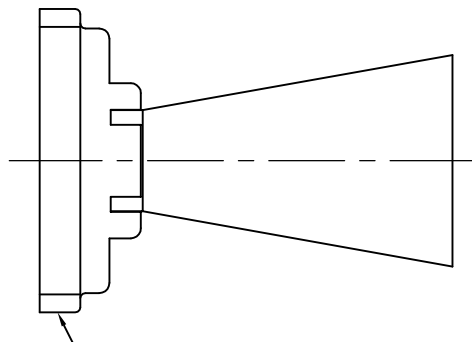

WR112 STD COVER FLANGE  
(UG-138/U)

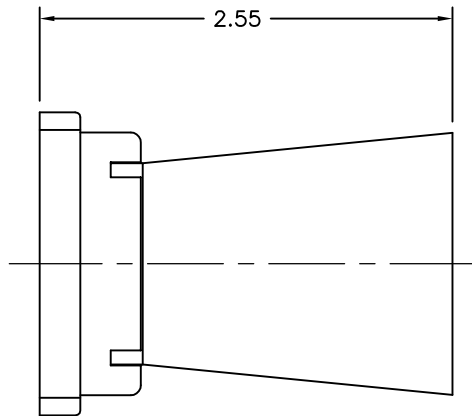
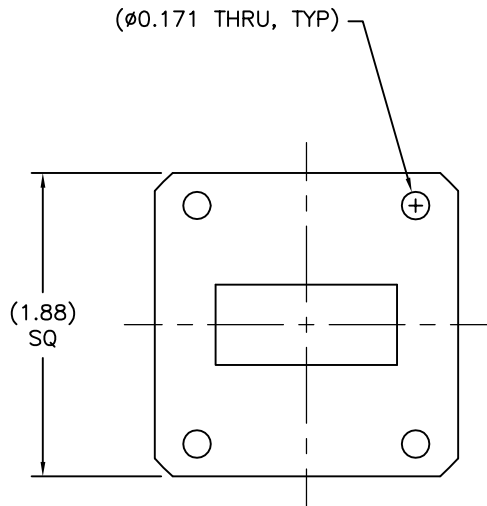
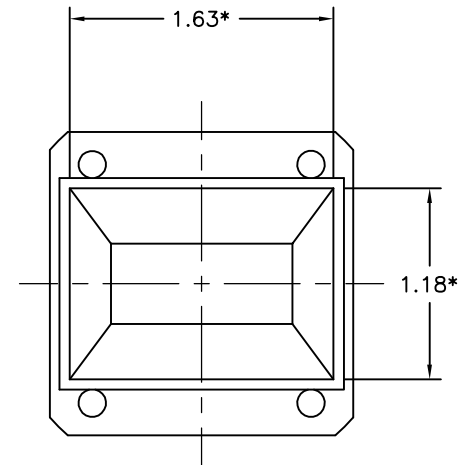

\*INSIDE DIMENSION

THIRD ANGLE PROJECTION:		APPROVALS		DATE		L-3 Narda - ATM		<small>THE INFORMATION IN THIS DRAWING IS PROPRIETARY AND SHALL NOT BE USED OR DISCLOSED WITHOUT THE PRIOR WRITTEN CONSENT OF ATM, INC. DO NOT SCALE DWG.</small>
UNLESS OTHERWISE NOTED, DIMENSIONS ARE IN INCHES, TOLERANCES ARE: FRACTIONS: ±1/64 ANGLES: ±1/2° MACHINED FINISH 63 ✓ OR BETTER		DRAWN D.M.		07/03/12		TEL: (631) 289-0363 FAX: (631) 289-0358 www.atmmicrowave.com		
		CHKD.			<b>OUTLINE</b> WR112 HORN - 10dB			
		APRVD.						
		MATERIAL ALUM ALLOY		SIZE A	CAGE CODE OR8N4	ATM DWG #	13976	REVISION C
		TREATMENT CHEM FILM		SCALE	1 : 1	MODEL #	112-440-6	SHEET 1/1