

REV A	AUTH RL	DATE 3/30/06	INITIAL RELEASE
REV B	AUTH RL	DATE 5/16/03	CORRECTED PRINTING PROBLEMS
REV C	AUTH RL	DATE 4/22/04	WR62 DIMS 1.24, 1.30, 1.03 WERE 1.05, 1.55, 1.05
REV D	AUTH RL	DATE 03/30/06	RE-ILLUSTRATED. DIMS FOR WR62, WR75, WR90, WR112 MODELS CHANGED PER ECN# 03-31-06-02

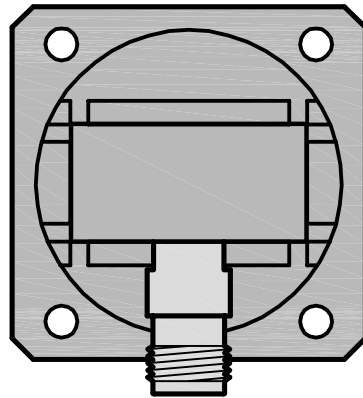

FLANGE PER REQUEST (COVER SHOWN)

TNC-F CONNECTOR
5/16-32 UNEF-2A THD.

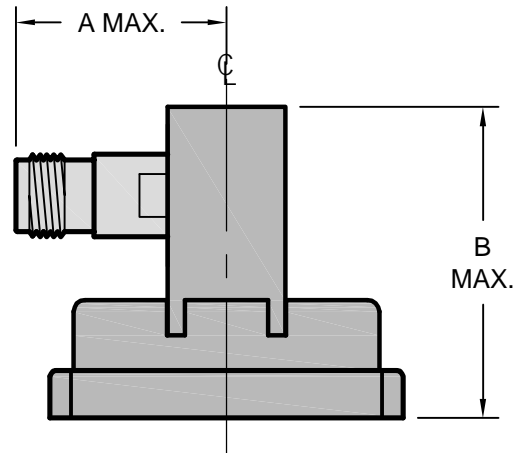
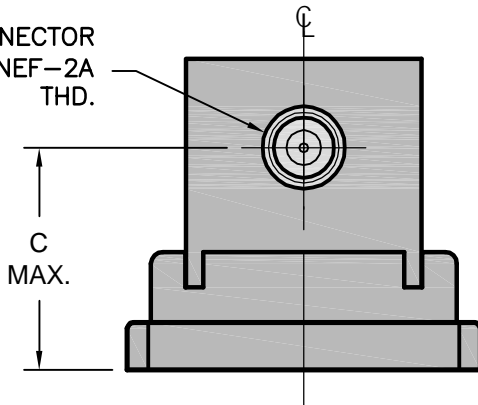

DIMENSIONS IN INCHES			
WG TYPE	A	B	C
WR62	1.16	1.00	0.65
WR75	1.17	1.00	0.63
WR90	1.17	1.00	0.63
WR102	1.17	1.64	1.14
WR112	1.23	1.14	0.67
WR137	1.10	2.00	1.47
WR159	1.19	2.33	1.70
WR187	1.23	2.60	1.90
WR229	1.36	2.25	1.35
WR284	1.48	2.50	1.51
WR340	1.66	3.50	2.29
WR430	1.88	4.00	2.30
WR650	2.43	5.00	2.40

THIRD ANGLE PROJECTION:	APPROVALS	DATE	ADVANCED TECHNICAL MATERIALS, INC. TEL: (631) 289-0363 FAX: (631) 289-0358 www.atmmicrowave.com		<small>THE INFORMATION IN THIS DRAWING IS PROPRIETARY AND SHALL NOT BE USED OR DISCLOSED WITHOUT THE PRIOR WRITTEN CONSENT OF ATM, INC. DO NOT SCALE DWG.</small>	
UNLESS OTHERWISE NOTED, DIMENSIONS ARE IN INCHES. TOLERANCES ARE: FRACTIONS: ±1/64 ANGLES: ±1/2°	DRAWN RL	03/30/06	OUTLINE, W/G-COAX ADAPTER, TNC-F			
	CHKD.					
	APRVD.					
	MATERIAL PER ORDER					
BASIC DIMENSION	DECIMALS 2 PLACE	3 PLACE	SIZE A	CAGE CODE OR8N4	ATM DWG # 3613W	REVISION D
UNDER 6"	±.02	±.005	SCALE	NONE	MODEL # SEE WEB	SHEET 1/1
6" - 12"	±.03	±.010				
OVER 12"	±.06	±.015				